

# TP-203A-CF-H1141-L100

## Temperature Detection – Probe

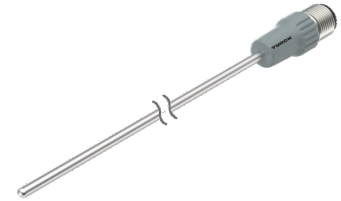
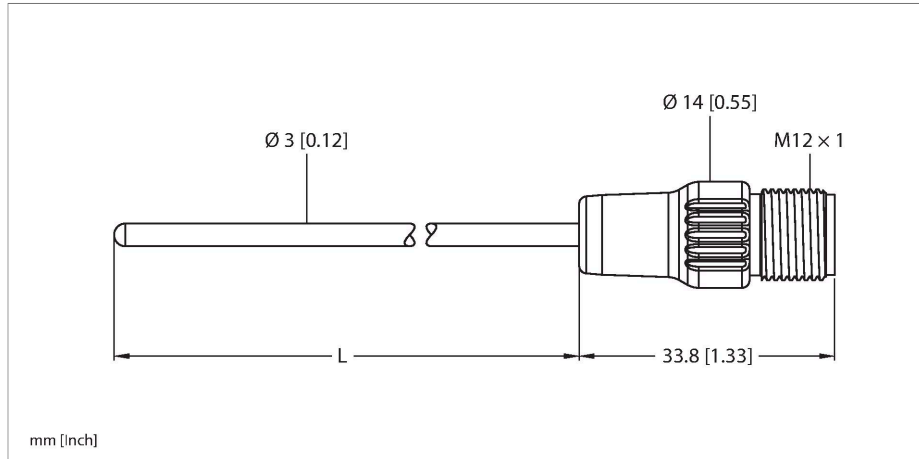

### Features

- Measuring element: Pt 100 temperature sensor, DIN EN 60 751, Class A
- Max. temperature connector: 120°C
- Connection mode: 4-wire connection
- Process connection via compression fitting or thermowell
- Bendable probe (min. bending radius: 3x outer diameter; excluding 30-mm probe tip)

### Wiring diagram

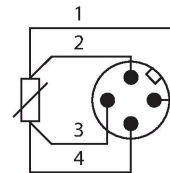

### Functional principle

Resistance thermometers are used for the detection and monitoring of temperatures to optimize and control a process. Typical applications are in machine and plant construction as well as in the process industry. The core element of the temperature probe is a temperature-dependent resistor.

### Technical data

Type	TP-203A-CF-H1141-L100
ID	9910402
<b>Temperature range</b>	
Measuring range	-50...500 °C
	-58...932 °F
Accuracy	±0.15 K + 0.002 •  t  (-30...300 °C)
Self-heating	0.4 K/mW at 0 °C
Measuring element	Pt100, DIN EN 60751, class A; connection mode: 4-wire connection
Response time	t 0.5 = 1.5 s / t 0.9 = 6.0 s in water at 0.2 m/s
Immersion depth L	100 mm
Outer diameter	3 mm
Protection class	IP67
<b>Environmental conditions</b>	
Ambient temperature	-40...+120 °C
Storage temperature	-40...+85 °C
<b>Mechanical data</b>	
Housing material	Stainless steel, 1.4404 (AISI 316L)
Sensor material	Stainless steel, 1.4404 (AISI 316L)
Process connection	For compression fittings, thermowell or direct mounting
Process Pressure	100 bar
Electrical connection	Connector, M12 × 1

## Technical data

Number of cores	4
Reference conditions acc. to IEC 61298-1	
Temperature	15...+25 °C
Atmospheric pressure	860...1060 hPa abs.
Humidity	45...75 % rel.
Auxiliary power	24 VDC
Tests/approvals	
Approvals	cULus
UL registration number	E345414
MTTF	2283 years acc. to SN 29500 (Ed. 99) 20 °C