

# RI360P0-QR24M0-0064X2-H1181

## Contactless Encoder – Incremental: 64 ppr

### Premium Line

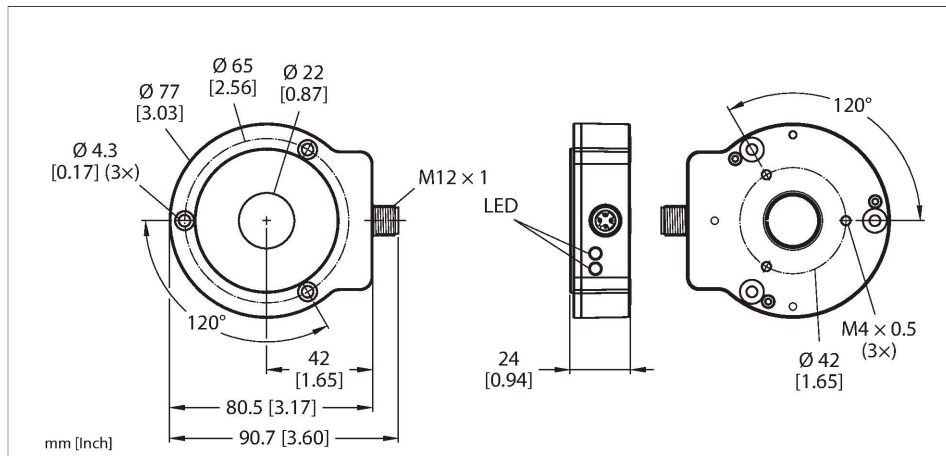

#### Technical data

Type	RI360P0-QR24M0-0064X2-H1181
ID	1593107
Measuring principle	Inductive
<b>General data</b>	
Max. rotational speed	10,000 rpm
	Determined with standardized construction, with a steel shaft Ø 20 mm, L = 50 mm and reducer Ø 20 mm.
Starting torque shaft load (radial / axial)	not applicable, because of contactless measuring principle
Nominal distance	1.5 mm
Repeat accuracy	≤ 0.01 % of full scale
Linearity deviation	≤ 0.05 % f.s.
Temperature drift	≤ ± 0.003 %/K
Output type	Incremental
Resolution incremental	64 ppr
<b>Electrical data</b>	
Operating voltage $U_b$	10...30 VDC
Ripple $U_{ss}$	≤ 10 % $U_{bmax}$
Isolation test voltage	0.5 kV
Short-circuit protection	yes/Cyclic
Wire break/reverse polarity protection	yes/yes (voltage supply)
Pulse frequency max.	200 kHz
Signal level high	min. $U_b$ - 2 V

#### Features

- Compact, rugged housing
- Many mounting possibilities
- Status displayed via LED
- Immune to electromagnetic interference
- Position of z-track can be set via Easy-Teach
- Burst function, absolute angular position output incrementally via Easy-Teach pulse
- 10...30 VDC
- Male M12 x 1, 8-pin
- Push-pull A, B, Z, A (inverse), B (inverse)

#### Wiring diagram

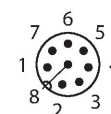
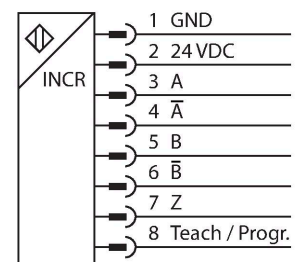

## Technical data

Signal level low	max. 2.0 V
Output function	8-pin, Push-Pull/HTL
Sample rate	1000 Hz
Current consumption	< 100 mA
<b>Mechanical data</b>	
Design	QR24
Dimensions	81 x 78 x 24 mm
Flange type	Flange without mounting element
Shaft Type	Hollow shaft
Shaft diameter D (mm)	6 6.35 9.525 10 12 12.7 14 15.875 19.05 20
Housing material	Metal/plastic, ZnAlCu1/PBT-GF30-V0
Electrical connection	Connector, M12 × 1
<b>Environmental conditions</b>	
Ambient temperature	-25...+85 °C Acc. to UL approval to +70 °C
Vibration resistance	55 Hz (1 mm)
Vibration resistance (EN 60068-2-6)	20 g; 10...3000 Hz; 50 cycles; 3 axes
Shock resistance (EN 60068-2-27)	100 g; 11 ms ½ sine; 3 × each; 3 axes
Continuous shock resistance (EN 60068-2-29)	40 g; 6 ms ½ sine; 4000 × each; 3 axes
Protection class	IP68 IP69K
MTTF	138 years acc. to SN 29500 (Ed. 99) 40 °C
Power-on indication	LED, Green
Measuring range display	LED, yellow, yellow flashing
Included in delivery	MT-QR24 mounting aid
UL certificate	E210608

## Functional principle

The measuring principle of inductive angle sensors is based on oscillation circuit coupling between the positioning element and the sensor, whereby an output signal is provided proportional to the angle of the positioning element. The rugged sensors are wear and maintenance-free, thanks to the contactless operating principle. They convince through their excellent repeatability, resolution and linearity within a broad temperature range. The innovative technology ensures a high immunity to electromagnetic DC and AC fields.

## Mounting instructions

Mounting instructions/Description

### A

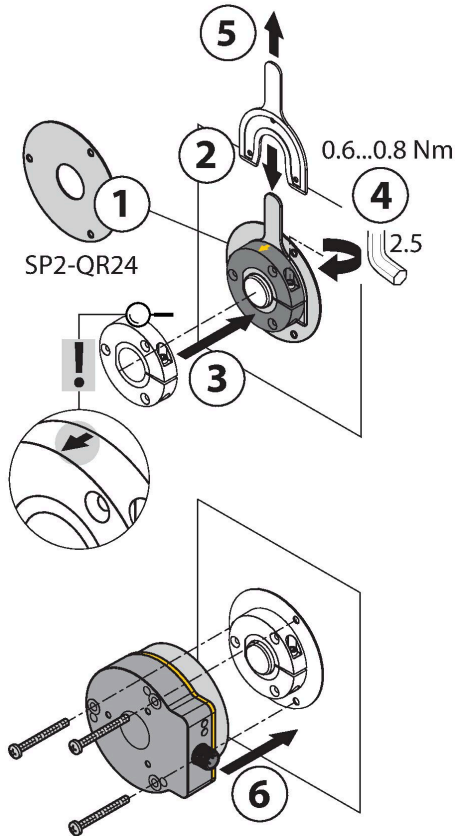

### B

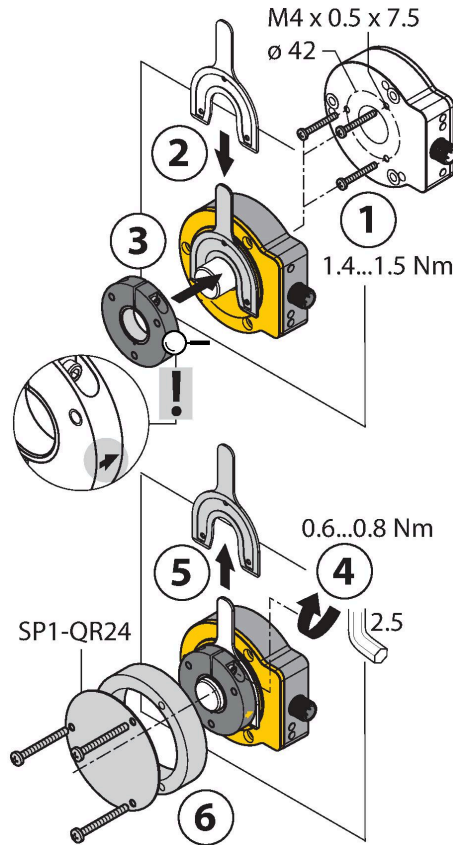

Extensive range of mounting accessories for easy adaptation to many different shaft diameters. Based on the functional principle of RLC coupling, the sensor operates absolutely wear-free and is immune to magnetized metal splinters and other interference fields. Wrong installation is hardly possible. The adjacent figure shows the two separate units, sensor and positioning element.

Mounting option A:

First, interconnect positioning element and rotatable shaft. Then place the encoder above the rotating part in such a way that you get a tight and protected unit.

Mounting option B:

Push the encoder on the back side of the shaft and fasten it to the machine. Then clamp the positioning element to the shaft with the bracket.

Mounting option C:

If the positioning element is to be screwed on a rotating machine part, use the RA0-QR24 plug which is included in the delivery. Then tie up the bracket. Screw on the encoder via the three bores.

The separately arranged sensor and positioning element inhibit that compensating currents or damaging mechanical loads are transmitted via the shaft to the sensor. In addition, the encoder remains tight and highly protected during its entire lifespan.

The accessories enclosed in the delivery help to mount encoder and positioning element at an optimal distance from each other. LEDs indicate the switching status.

Status display via LED

green steady:

Optimal sensor supply

yellow steady:

Positioning element has reached the end of the measuring range. This is indicated by a lower signal quality.

yellow flashing:

Positioning element is outside the measuring range.

off:

Positioning element is in the measuring range.

### C

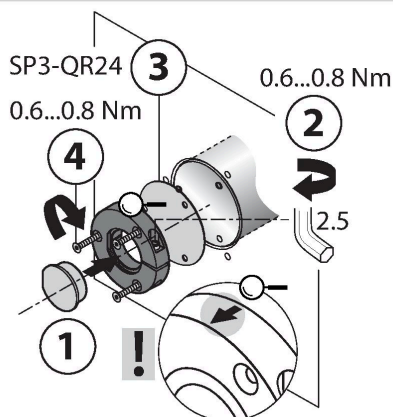

### Default: 0°

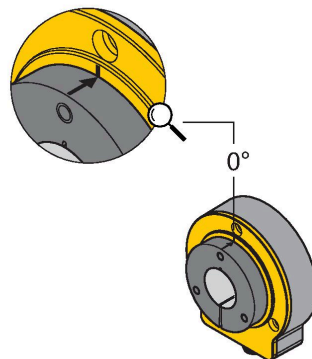



## Individual Parameterization (Teaching with Positioning Element)

Jumper between teach input Pin 8	Gnd Pin 1	Ub Pin 2	LED
2 s	Z-track zero point teaching	One-time triggering of burst function	Status LED flashes then turns steady after 2 s
10 s	CCW rotation direction	CW rotation direction	After 10 s status LED flashes fast for 2 s
15 s	-	Factory setting (z-track, CW)	After 15 s power and status LED alternate

To avoid unintended teaching, keep pin 8 potential-free.

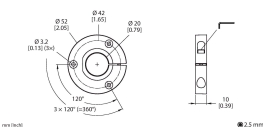
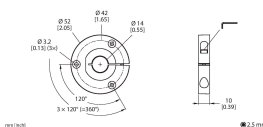
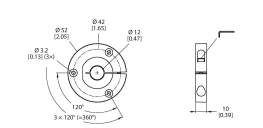
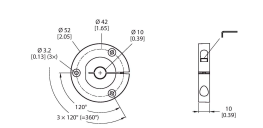
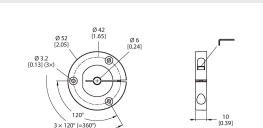
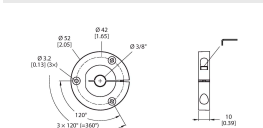
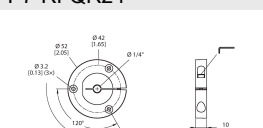
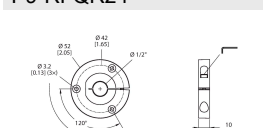
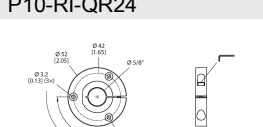
## Accessories

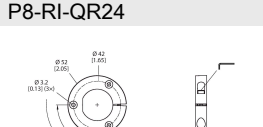
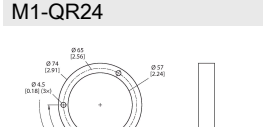
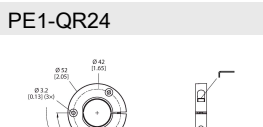
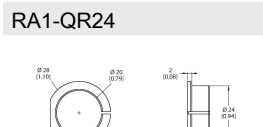
<b>P1-RI-QR24</b>  Positioning element, for Ø 20 mm shafts	<b>1590921</b>	<b>P2-RI-QR24</b>  Positioning element, for Ø 14 mm shafts	<b>1590922</b>
<b>P3-RI-QR24</b>  Positioning element, for Ø 12 mm shafts	<b>1590923</b>	<b>P4-RI-QR24</b>  Positioning element, for Ø 10 mm shafts	<b>1590924</b>
<b>P5-RI-QR24</b>  Positioning element, for Ø 6 mm shafts	<b>1590925</b>	<b>P6-RI-QR24</b>  Positioning element, for Ø 3/8" shafts	<b>1590926</b>
<b>P7-RI-QR24</b>  Positioning element, for Ø 1/4" shafts	<b>1590927</b>	<b>P9-RI-QR24</b>  Positioning element for installation on Ø 1/2" shafts	<b>1593012</b>
<b>P10-RI-QR24</b>  Positioning element for installation on Ø 5/8" shafts	<b>1593013</b>	<b>P11-RI-QR24</b>  Positioning element for installation on Ø 3/4" shafts	<b>1593014</b>
<b>P8-RI-QR24</b>  Positioning element with blanking plug for large shafts	<b>1590916</b>	<b>M1-QR24</b>  Aluminum protecting ring, for inductive encoders RI-QR24	<b>1590920</b>
<b>PE1-QR24</b>  Positioning element without adapter sleeve	<b>1590937</b>	<b>RA1-QR24</b>  Adapter sleeve, for Ø 20 mm shafts	<b>1590928</b>

**RA2-QR24** 1590929  
Adapter sleeve, for Ø 14 mm shafts

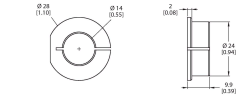

**RA3-QR24** 1590930  
Adapter sleeve, for Ø 12 mm shafts

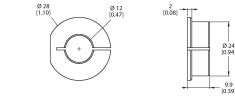

**RA4-QR24** 1590931  
Adapter sleeve, for Ø 10 mm shafts

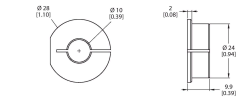

**RA5-QR24** 1590932  
Adapter sleeve, for Ø 6 mm shafts

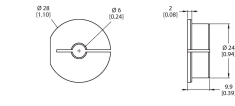

**RA6-QR24** 1590933  
Adapter sleeve, for Ø 3/8" shafts

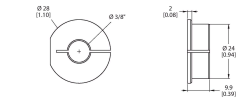

**RA7-QR24** 1590934  
Adapter sleeve, for Ø 1/4" shafts

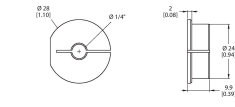

**RA9-QR24** 1590960  
Adapter sleeve, for Ø 1/2" shafts

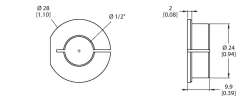

**RA10-QR24** 1590961  
Adapter sleeve, for Ø 5/8" shafts

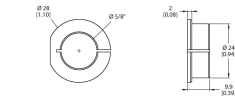

**RA11-QR24** 1590962  
Adapter sleeve, for Ø 3/4" shafts

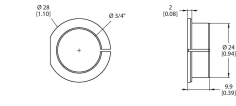

**RA8-QR24** 1590959  
Plug for mounting option C

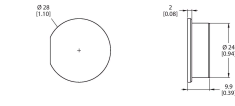

**SP1-QR24** 1590938  
Shield plate Ø 74 mm, aluminium

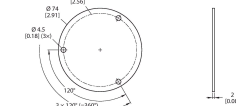

**SP2-QR24** 1590939  
Shield plate Ø 74 mm, aluminium, with borehole for shaft feedthrough

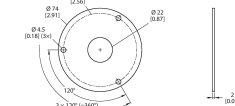

**SP3-QR24** 1590958  
Shield plate Ø 52 mm, aluminium

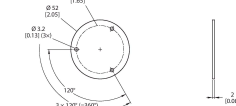

**MT-QR24** 1590935  
Mounting aid for optimal alignment of positioning element

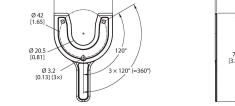

## Wiring accessories

Dimension drawing	Type	ID	
	RKC8T-2/TXL	6625142	Connection cable, M12 female connector, straight, 8-pin, cable length: 2 m, jacket material: PUR, black; cULus approval

RI360P0-QR24M0-0064X2-H1181 | 02/21/2025 14-59 | technical changes reserved

Dimension drawing

Type

E-RKC 8T-264-2

ID

U-04781

Connection cable, female M12, straight, 8-pin (twisted pairs), shielded, cable length: 2 m, sheath material: PVC, black; cULus approval; other cable lengths and qualities available, see [www.turck.com](http://www.turck.com)

