

# RI360P0-EQR24M0-IOLX2-H1141

## Contactless Encoder with Stainless Steel Housing – IO-Link Premium Line

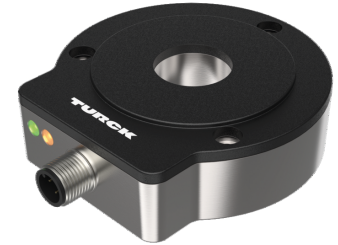
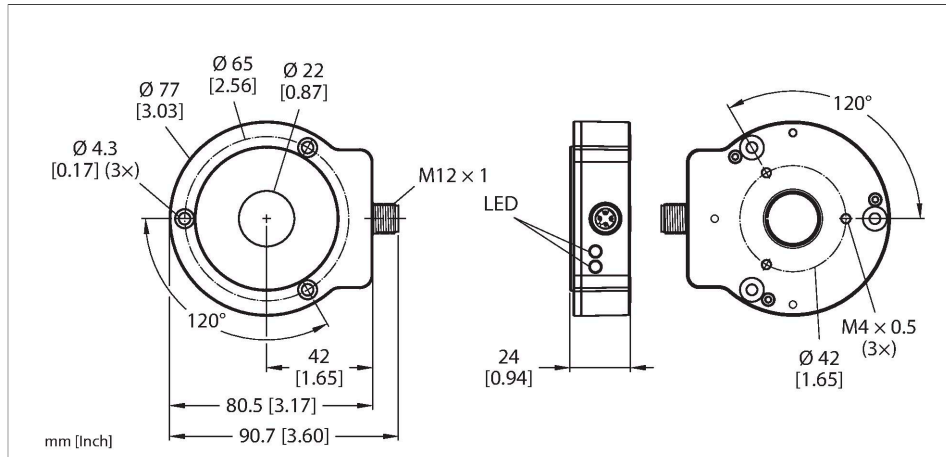

### Technical data

Type	RI360P0-EQR24M0-IOLX2-H1141
ID	1590978
Measuring principle	Inductive
<b>General data</b>	
Max. Rotational Speed	800 rpm
Starting torque shaft load (radial / axial)	Determined with standardized construction, with a steel shaft Ø 20 mm, L = 50 mm and reducer Ø 20 mm
Measuring range	0...360 °
Nominal distance	1.5 mm
Repeat accuracy	≤ 0.01 % of full scale
Linearity deviation	≤ 0.05 % f.s.
Temperature drift	≤ ± 0.003 %/K
Output type	Absolute semi-multiturn
Resolution singleturn	16 bit/65,536 units per revolution
Resolution multiturn	13 bit/8192 revolutions
Number of diagnostic bits	3 Bit
<b>Electrical data</b>	
Operating voltage	15...30 VDC
Residual ripple	≤ 10 % U <sub>ss</sub>
Isolation test voltage	≤ 0.5 kV
Wire breakage/Reverse polarity protection	yes (voltage supply)

### Features

- Compact, rugged housing
- Active face, plastic PA12-GF30
- Housing, stainless steel V4A (1.4404)
- Status displayed via LED
- Immune to electromagnetic interference
- 16 bits singleturn
- Process value in 32 bit IO-Link telegram
- 3 error bits
- 16 bits singleturn
- 13 bits multiturn
- 15...30 VDC
- M12 × 1 male connector, 4-pin

### Wiring diagram

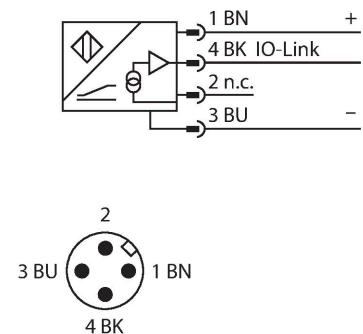

### Functional principle

The measuring principle of inductive encoders is based on oscillation circuit coupling

## Technical data

Communication protocol	IO-Link
Sample rate	1000 Hz
Current consumption	< 50 mA
<b>IO-Link</b>	
IO-Link specification	V 1.1
Programming	FDT/DTM
Communication mode	COM 2 (38.4 kBaud)
Process data width	32 bit
Minimum cycle time	3 ms
Function pin 4	IO-Link
Included in the SIDI GSDML	Yes
<b>Mechanical data</b>	
Design	EQR24
Dimensions	81 x 78 x 24 mm
Flange type	Flange without mounting element
Shaft Type	Hollow shaft
Shaft diameter D [mm]	6 6.35 9.525 10 12 12.7 14 15.875 19.05 20
Housing material	Stainless-steel/Plastic, 1.4404 (AISI 316L)/PA12-GF30
Electrical connection	Connector, M12 × 1
<b>Environmental conditions</b>	
Ambient temperature	-25...+85 °C
	Acc. to UL approval to +70 °C
Vibration resistance	55 Hz (1 mm)
Vibration resistance (EN 60068-2-6)	20 g; 10...3000 Hz; 50 cycles; 3 axes
Shock resistance (EN 60068-2-27)	100 g; 11 ms ½ sine; 3 × each; 3 axes
Continuous shock resistance (EN 60068-2-29)	40 g; 6 ms ½ sine; 4000 × each; 3 axes
Protection class	IP68 IP69K
MTTF	138 years acc. to SN 29500 (Ed. 99) 40 °C
Power-on indication	LED, Green
Measuring range display	LED, yellow, yellow flashing

between the positioning element and the sensor, whereby an output signal is provided proportional to the angle of the positioning element. Turck refers to semi-multiturn because the multiturn process data is calculated internally from the number of single-turn zero passes. Because the sensor does not detect any revolutions when not supplied with power, the plausibility of the multiturn process data is indicated by a diagnostic bit. The rugged sensors are maintenance- and wear-free thanks to the contactless operating principle. They convince through their excellent repeatability, resolution and linearity within a broad temperature range. The innovative technology ensures high immunity to electromagnetic DC and AC fields.

## Technical data

Included in delivery

Adapter sleeve MT-QR24

## Mounting instructions

Mounting instructions/Description

### A

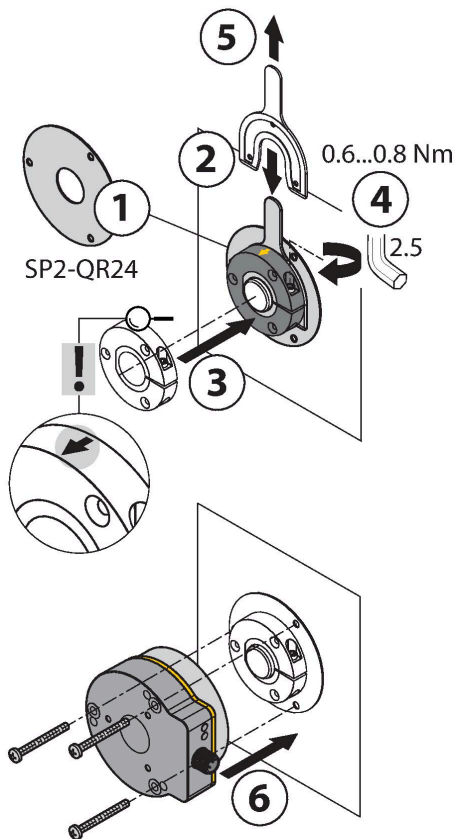

### B

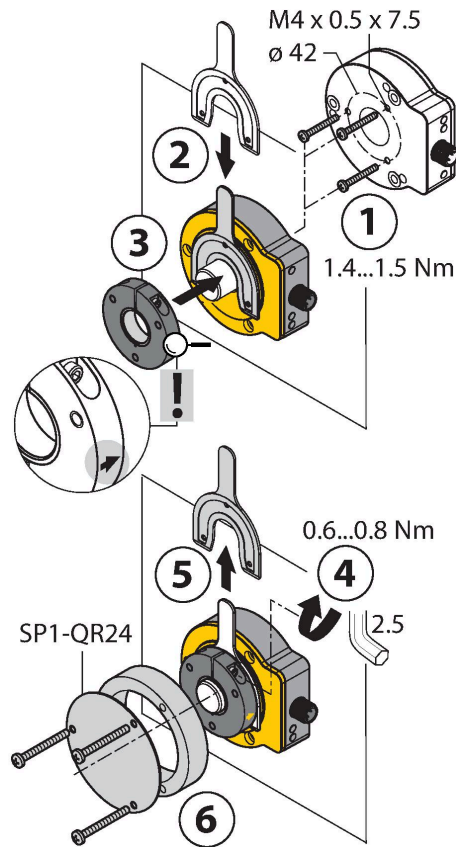

### C

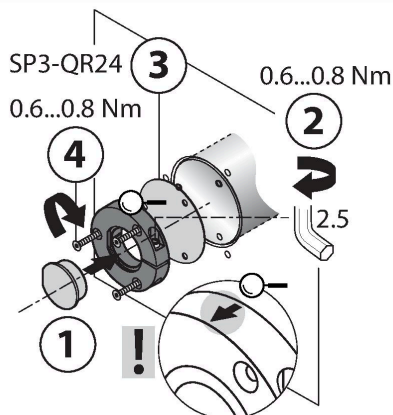

### Default: 0°

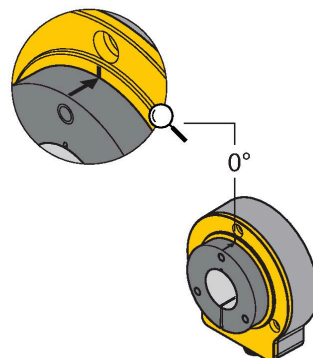

Extensive range of mounting accessories for easy adaptation to many different shaft diameters. Based on the functional principle of RLC coupling, the sensor operates absolutely wear-free and is immune to magnetized metal splinters and other interference fields. Wrong installation is hardly possible.

The adjacent figure shows the two separate units, sensor and positioning element.

Mounting option A:

First, interconnect positioning element and rotatable shaft. Then place the encoder above the rotating part in such a way that you get a tight and protected unit.

Mounting option B:

Push the encoder on the back site of the shaft and fasten it to the machine. Then clamp the positioning element to the shaft with the bracket.

Mounting option C:

If the positioning element is to be screwed on a rotating machine part and not on a shaft, install first the dummy plug RA8-QR24. Then tie up the bracket. Screw on the encoder via the three bores.

The separately arranged sensor and positioning element inhibit that compensating currents or damaging mechanical loads are transmitted via the shaft to the sensor. In addition, the encoder remains tight and highly protected during its entire lifespan.

The accessories enclosed in the delivery help to mount encoder and positioning element at an optimal distance from each other. LEDs indicate the switching status. Optionally, you can use the shields which are included in the accessories to increase the allowed distance between positioning element and sensor.

Status display via LED

green steady:

Sensor is operative

yellow steady:

Positioning element has reached the end of the measuring range. This is indicated by a weaker signal.

yellow flashing:

Positioning element is outside the measuring range.

off:

Positioning element is in the measuring range

## Accessories

PE1-EQR24

1590966

Positioning element with stainless steel compression fitting, without adapter sleeve

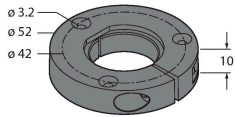

M5-QR24

1590965

Plastic protecting ring for encoders RI-EQR24

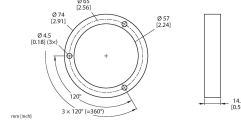

RA1-EQR24

1593019

Stainless steel adapter sleeve, for Ø 20 mm shafts

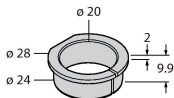

RA3-EQR24

1593020

Stainless steel adapter sleeve, for Ø 12 mm shafts

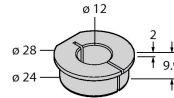

RA4-EQR24

1593023

Stainless steel adapter sleeve, for Ø 10 mm shafts

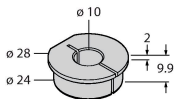

RA5-EQR24

100000375

Stainless steel adapter sleeve, for Ø 6 mm shafts

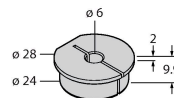

RA8-EQR24

100000289

Stainless steel plug for mounting option C



SP1-EQR24

1590979

Shield plate Ø 74 mm, stainless steel

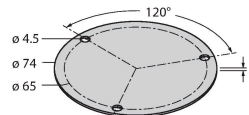

SP5-QR24

100003689

Protective plate Ø 74 mm, plastic

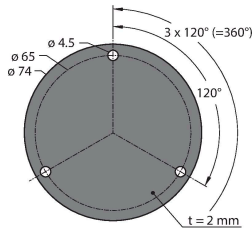

## Wiring accessories

Dimension drawing	Type	ID	
	RKCV4T-2/TXL	6627934	Connection cable, M12 female connector, straight, 3-pin, cable length: 2 m, jacket material: PUR, black; stainless steel coupling nut; cULus approval
	RKH4-2/TFG	6934384	Connection cable, M12 female connector, straight, 3-pin, stainless steel coupling nut, cable length: 2 m, jacket material: TPE, gray; temperature range: -40...+105 °C