

WIM45-UNTL-LIU5X2-0.3-RS4

Linear Position Sensor – For Analog Monitoring of Pneumatic Cylinders

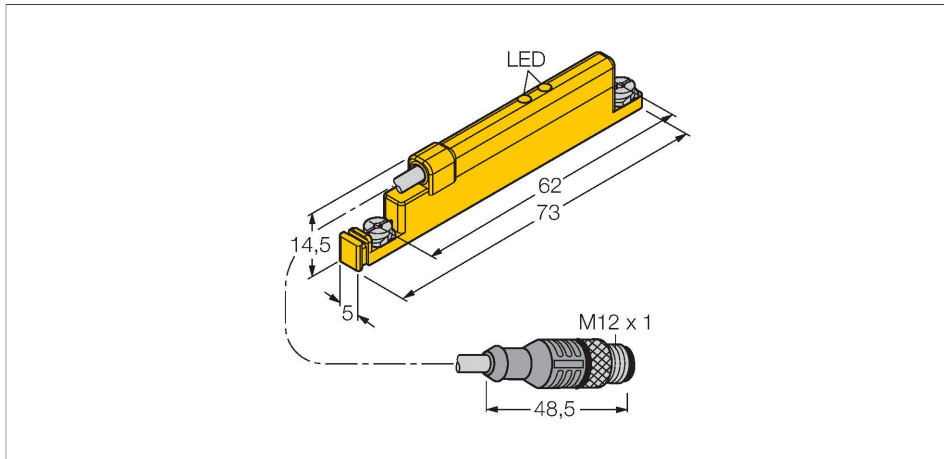

Features

- Plastic, PA12-GF30
- For direct mounting on pneumatic T-groove cylinders
- Magnetic field status displayed via two LEDs
- Measured value storage
- Hardly affected by external magnetic fields
- 4-wire, 15...30 VDC
- 0...10 V and 4...20 mA
- Pigtail with male end, M12 x 1

Wiring diagram

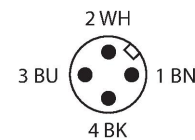
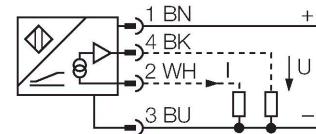

Technical data

| | |
|--|--|
| Type | WIM45-UNTL-LIU5X2-0.3-RS4 |
| ID | 1536621 |
| Measuring principle | Magnetic |
| General data | |
| Measuring range | 45 mm |
| Resolution | 0.045 mm/10 bit |
| Repeatability | ≤ 0.1% of measuring range IA - BI with non-rotatable piston rod |
| Reproducibility | ≤ 45 μm |
| Linearity deviation | ≤ 1 % |
| Temperature drift | ≤ ± 0.006 %/K |
| Electrical data | |
| Operating voltage U_B | 15...30 VDC |
| Ripple U_{ss} | ≤ 10 % U_{Bmax} |
| No-load current | ≤ 15 mA |
| Isolation test voltage | 0.5 kV |
| Short-circuit protection | yes |
| Wire break/reverse polarity protection | yes/Complete |
| Output function | 4-wire, Analog output |
| Voltage output | 0...10 V |
| Current output | 4...20 mA |
| Load resistance voltage output | ≥ 4.7 kΩ |
| Load resistance current output | ≤ 0.4 kΩ |

Functional principle

Magnetic inductive linear position sensors with analog output accomplish control tasks by providing a signal proportional to the position of the piston rod. The polarity of the magnet has no effect on the output signal. The outstanding features of these robust sensors are excellent repeatability, resolution and linearity, excellent electromagnetic capability and a broad temperature range.

Technical data

| Mechanical data | |
|--------------------------------|-------------------------------|
| Design | UNTL |
| Dimensions | 73 x 5 x 14.5 mm |
| Housing material | Plastic, PA12-GF30 |
| Tightening torque fixing screw | 0.4 Nm |
| Electrical connection | Cable with connector, M12 × 1 |
| Cable quality | 0.3 m |
| Environmental conditions | |
| Ambient temperature | -25...+70 °C |
| Vibration resistance | 55 Hz (1 mm) |
| Shock resistance | 30 g (11 ms) |
| Protection class | IP67 |
| Display magnetic-field status | 2x LED, yellow |

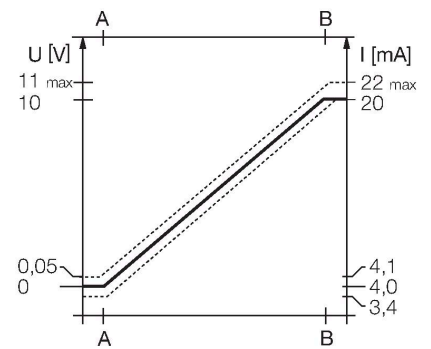

Mounting instructions

Mounting instructions/Description

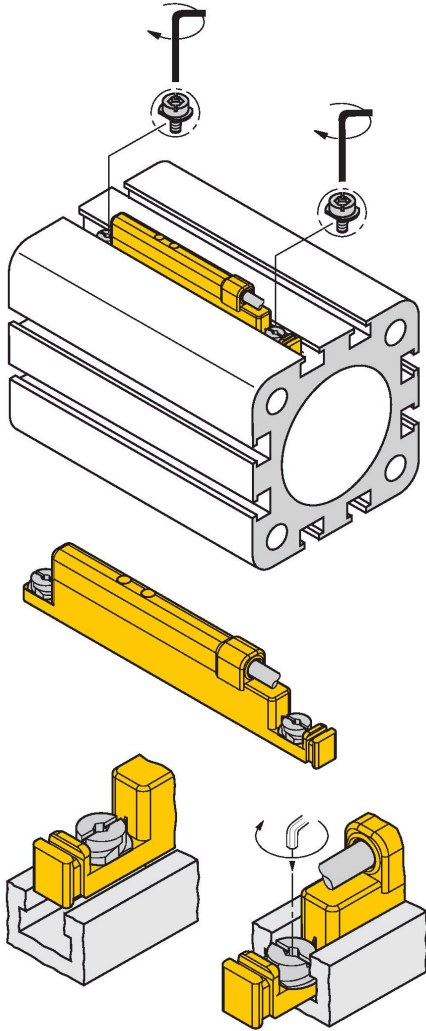

Thanks to the mounting lip, the sensor can be inserted into the groove from above with one hand. The sensor is mounted as follows: Turn the screw clockwise. The sensor is pressed down and thus locked. A quarter turn of the screw with a slotted screwdriver (blade thickness 0.5 mm) or 1.5 mm Allen key is sufficient to fasten the sensor so that it doesn't vibrate. A tightening torque of 0.4 Nm is sufficient for secure mounting without damaging the cylinder. A cable clip is included in the scope of delivery. It enables smooth cable routing in the groove and ensures that the cable is fastened as securely as possible. The corresponding accessories for mounting on other cylindrical housings must be ordered separately.

LEDs:

If both LEDs are on, the magnet is in the measuring range of the sensor and the magnetic field has optional magnetizing force; accuracy and linearity of the output curve are within the specified range.

If only one LED is on, the magnet is within the measuring range, but the magnetizing force is not ideal; the output characteristic may be outside the specified range.

If both LEDs are off, no magnet is in the measuring range of the sensor.

Wiring accessories

Dimension drawing

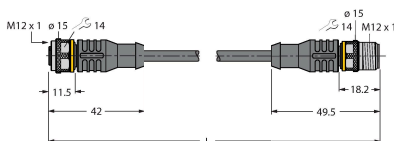

Type

RKC4.301T-0.15-RSC4.334T/TXL 6631382

ID

Extension cable, M12 female/male, straight, 4-pin, cable length: 0.15m, jacket material: PUR, black; cULus approval; Adapter cable for sensors with analog output on pin 2, for connection to analog inputs of fieldbus modules with 4-wire technology