

# B1N360V-Q20L60-2UP6X3-H1151

## Inclinometer – With two Programmable Switching Points

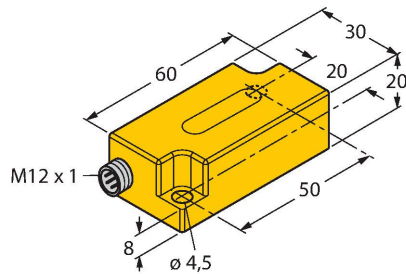

### Features

- Rectangular, height 20 mm
- Plastic, PC
- Indication of operating voltage and switching state
- Two programmable switching outputs
- Switchpoints selectable in a range between 0° and 360°
- DC 4-wire, 10...30 VDC
- M12 x 1 male connector

### Wiring diagram

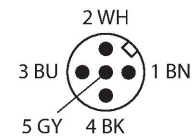
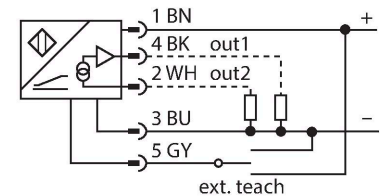

### Technical data

Type	B1N360V-Q20L60-2UP6X3-H1151
ID	1534051
Measuring principle	Acceleration
<b>General data</b>	
Measuring range	0...360 °
measuring range z-axis	0...360 °
Number of measuring axes	1
Mounting conditions	Vertical
Repeat accuracy	≤ 0.2 % of full scale
Absolute accuracy	± 0.5 ° At 25 °C
Temperature coefficient typical	0.03 °/K
Resolution	≤ 0.14 °
<b>Electrical data</b>	
Operating voltage	10...30 VDC
Residual ripple	≤ 10 % U <sub>ss</sub>
Residual current	≤ 0.1 mA
Isolation test voltage	≤ 0.5 kV
Output current	≤ 500 mA
Response delay	500 ms
Dropout delay	350 ms
Short-circuit protection	yes / Thermal
Wire breakage/Reverse polarity protection	yes / Complete
Output function	5-pin, NO/NC, 2 × PNP
	Surge protection from +U <sub>b</sub> to (U <sub>b</sub> - 40V)

### Functional principle

Inclination is determined by a wear-free semiconducting sensor element.

## Technical data

Current consumption	35 mA
<b>Mechanical data</b>	
Design	Rectangular, Q20L60
Dimensions	60 x 30 x 20 mm
Housing material	Plastic, PC
Electrical connection	Connector, M12 x 1
<b>Environmental conditions</b>	
Ambient temperature	-30...+70 °C
Vibration resistance	55 Hz (1 mm)
Shock resistance	30 g (11 ms)
Protection class	IP68 IP69K
MTTF	399 years acc. to SN 29500 (Ed. 99) 40 °C
Power-on indication	LED, Green
Switching state	2 x LEDs, Yellow

## Mounting instructions

### Mounting instructions/Description

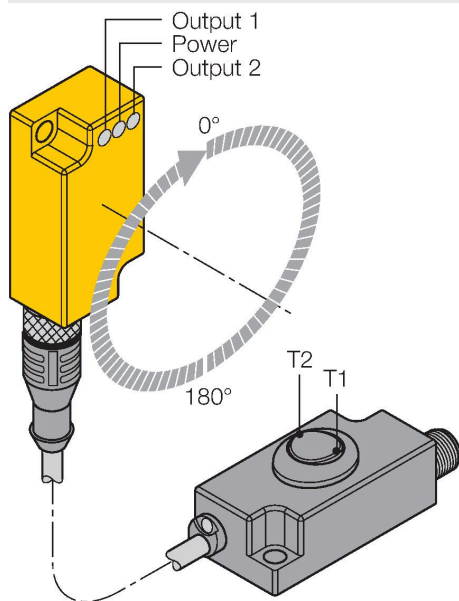

The switchpoints are set with the TX1-Q20L60 teach adapter

By actuating the toggle switch T1 (OUT 1), a bridge is formed between GND and pin 5.  
By actuating the toggle switch T2 (OUT 2), a bridge is formed between UB and pin 5.  
The switch-on and off points are freely selectable within 360° degrees.

You can teach-in the switching points either clockwise or counter-clockwise.

Before programming the wanted switch-on and off points, move the sensor in start position. For details on programming, please see next page. Should you wish to set the switch-off point yourself, the sensor must also be positioned at this point. The sensor must be installed in vertical position.

A further programming method has already a preset range of 180°. Here, only the switch-on point must be set.

## Accessories

GUARD-Q20L60

A9684

Protective housing for Q20L60  
inclinometers for protecting against  
mechanical impact; material:  
Stainless steel

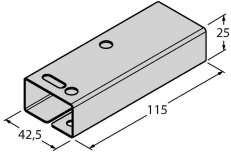

**Instructions for use**

Switchpoint adjustable as NO contact counter-clockwise or as NC contact clockwise

Press T1 (T2) for 5 s

Power LED flashes

Place the sensor in the wanted start position

Press T1 (T2) for 1 s to set the switch-on point

Power LED and Output 1 (2) LED flash

Place the sensor in the wanted end position

Press T1 (T2) for 3 s to set the switch-off point

Power LED and Output 1 (2) LED flash for 3 s then turn steady

Teach process completed, sensor ready for operation.

Switchpoint adjustable as NO contact clockwise or as NC contact counter-clockwise

Press T1 (T2) for 5 s

Power LED flashes

Place the sensor in the wanted start position

Press T1 (T2) for 3 s to set the switch-on point

Power LED and Output 1 (2) LED flash fast

Place the sensor in the wanted end position

Press T1 (T2) for 1 s to set the switch-off point

Power LED and Output 1 (2) LED flash for 3 s then turn steady

Teach process completed, sensor ready for operation.

Switchpoint adjustable as NO contact counter-clockwise or as NC contact clockwise (180° default setting)

Press T1 (T2) for 5 s

Power LED flashes

Place the sensor in the wanted start position

Press T1 (T2) for 1 s to set the switch-on point

Power LED and Output 1 (2) LED flash

Press T1 (T2) for 1 s to set the travel path 180 ° and the hysteresis 1 °

Power LED and Output 1 (2) LED flash for 3 s then turn steady

Teach process completed, sensor ready for operation.

Switchpoint adjustable as NO contact clockwise or as NC contact counter-clockwise (180° default setting)

Press T1 (T2) for 5 s

Power LED flashes

Place the sensor in the wanted start position

Press T1 (T2) for 3 s to set the switch-on point

Power LED and Output 1 (2) LED flash fast

Press T1 (T2) for 3 s to set the travel path 180 ° and the hysteresis 1 °

Power LED and Output 1 (2) LED flash for 3 s then turn steady

Teach process completed, sensor ready for operation.

T1 = Switching output 1; T2 = Switching output 2

Default settings:

Hysteresis 1°

**Instructions for use**

Switchpoint adjustable as NO contact counter-clockwise or as NC contact clockwise

Press T1 (T2) for 5 s

Power LED flashes

Place the sensor in the wanted start position

Press T1 (T2) for 1 s to set the switch-on point

Power LED and Output 1 (2) LED flash

Place the sensor in the wanted end position

Press T1 (T2) for 3 s to set the switch-off point

Power LED and Output 1 (2) LED flash for 3 s then turn steady

Teach process completed, sensor ready for operation.

Switchpoint adjustable as NO contact clockwise or as NC contact counter-clockwise

Press T1 (T2) for 5 s

Power LED flashes

Place the sensor in the wanted start position

Press T1 (T2) for 3 s to set the switch-on point

Power LED and Output 1 (2) LED flash fast

Place the sensor in the wanted end position

Press T1 (T2) for 1 s to set the switch-off point

Power LED and Output 1 (2) LED flash for 3 s then turn steady

Teach process completed, sensor ready for operation.

Switchpoint adjustable as NO contact counter-clockwise or as NC contact clockwise (180° default setting)

Press T1 (T2) for 5 s

Power LED flashes

Place the sensor in the wanted start position

Press T1 (T2) for 1 s to set the switch-on point

Power LED and Output 1 (2) LED flash

Press T1 (T2) for 1 s to set the travel path 180 ° and the hysteresis 1 °

Power LED and Output 1 (2) LED flash for 3 s then turn steady

Teach process completed, sensor ready for operation.

Switchpoint adjustable as NO contact clockwise or as NC contact counter-clockwise (180° default setting)

Press T1 (T2) for 5 s

Power LED flashes

Place the sensor in the wanted start position

Press T1 (T2) for 3 s to set the switch-on point

Power LED and Output 1 (2) LED flash fast

Press T1 (T2) for 3 s to set the travel path 180 ° and the hysteresis 1 °

Power LED and Output 1 (2) LED flash for 3 s then turn steady

Teach process completed, sensor ready for operation.

T1 = Switching output 1; T2 = Switching output 2

Default settings:

Hysteresis 1°