

# RI360P1-QR20-9F16B-0.3-DT04-4PMB

## Miniature encoder – With J1939 Output

### Premium Line

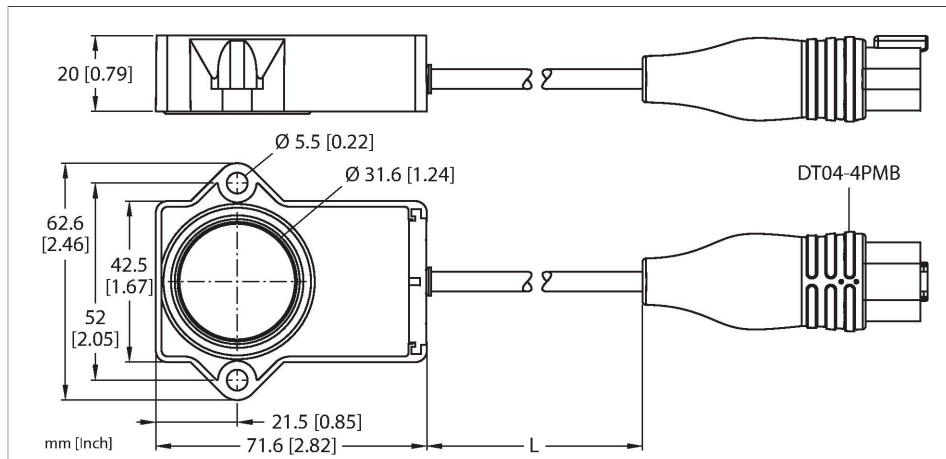

### Technical data

Type	RI360P1-QR20-9F16B-0.3-DT04-4PMB
ID	100027368
Measuring principle	Inductive
<b>General data</b>	
Max. rotational speed	3000 rpm
Starting torque shaft load (radial / axial)	Not applicable because of contactless measuring principle
Resolution	0.09°
Measuring range	0...360 °
Nominal distance	1 mm
Repeat accuracy	≤ 0.025 % of full scale
Speed deviation	± 10 rpm
Linearity deviation	≤ 0.3 % f.s.
Output type	Absolute singleturn
<b>Electrical data</b>	
Operating voltage $U_b$	8...30 VDC
Ripple $U_{rs}$	≤ 10 % $U_{Bmax}$
Isolation test voltage	0.5 kV
Short-circuit protection	yes
Wire break/reverse polarity protection	yes
Communication protocol	SAE J1939
Baud rate	250 kbps
Sample rate	800 Hz

### Features

- Rectangular, plastic
- Compact and robust housing
- Versatile mounting possibilities
- Positioning element P1-RI-QR20 included in delivery
- For vehicle electrical systems, 12 V and 24 V
- Increased interference immunity 100 V/m following the e1 type approval
- Protection against conducted interference acc. to DIN ISO 7637-2 (SAE J 113-11)
- Extended temperature range
- High protection class IP68/IP69K
- Protection against salt spray and rapid temperature change
- Measuring range displayed via LED
- Immune to electromagnetic interference
- Resolution: 0.09°
- 8...30 VDC
- J1939
- Male connector, Deutsch DT04-4PMB

### Wiring diagram

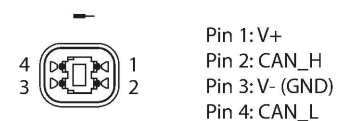

### Functional principle

The measuring principle of inductive angle sensors is based on oscillation circuit coupling between the positioning element and the

RI360P1-QR20-9F16B-0.3-DT04-4PMB 02/21/2025 15-05 | technical changes reserved

## Technical data

Load dump protection	ISO 16750-2: Impuls 5a: 151 V, Impuls 5b: 58 V, Kriterium A
Current consumption	< 50 mA
<b>Mechanical data</b>	
Design	Rectangular, QR20
Dimensions	71.6 x 62.6 x 20 mm
Flange type	Flange without mounting element
Shaft Type	Blind hole shaft
Shaft diameter D (mm)	6 6.35
Housing material	Plastic, Ultem
Cable quality	Ø 5.7 mm, 0.4 m
Core cross-section	5 x 0.2 mm <sup>2</sup>
<b>Environmental conditions</b>	
Ambient temperature	-40...+85 °C
Storage temperature	-40...+125 °C
Temperature changes (EN60068-2-14)	-40... +85 °C; 20 cycles
Vibration resistance	55 Hz (1 mm)
Vibration resistance (EN 60068-2-6)	20 g; 10...3000 Hz; 50 cycles; 3 axes
Shock resistance (EN 60068-2-27)	100 g; 11 ms ½ sine; 3 × each; 3 axes
Continuous shock resistance (EN 60068-2-29)	40 g; 6 ms ½ sine; 4000 × each; 3 axes
Salt spray test (EN 60068-2-52)	Severity degree 5 (4 test cycles)
Protection class	IP68 IP69K
MTTF	423 years acc. to SN 29500 (Ed. 99) 40 °C
Power-on indication	LED, Green
Measuring range display	multifunction LED, green green flashing
Included in delivery	Positioning element P1-RI-QR20; for technical details see data sheet

sensor, whereby an output signal is provided proportional to the angle of the positioning element. The rugged sensors are wear and maintenance-free, thanks to the contactless operating principle. They convince through their excellent repeatability, resolution and linearity within a broad temperature range. The innovative technology ensures a high immunity to electromagnetic DC and AC fields.

## Mounting instructions

### Mounting instructions/Description

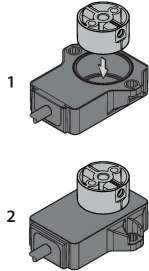

There are two different mounting options. One option is to position the positioning element above the sensor housing. However, it can also be mounted so that the sensor housing completely encloses the positioning element.

#### LED function

Operating voltage

Green: Power on

Displayed measuring range

Green: Positioning element is in the detection range

Green flashing: Positioning element is within the measuring range, low signal intensity (e.g. distance too large)

Off: Positioning element is outside the detection range

Inductive measuring principle provides more safety

Due to the measuring principle, which is based on the functional principle of an RLC coupling, the sensor operates absolutely wear-free and is immune to magnetized ironware and other interferences. The amplitude of the signal can be changed by metal parts, which in turn affects the accuracy.

Owing to the differential analysis, the output signal remains almost unchanged, even if the position of the positioning element deviates from the ideal axis of rotation. The distance between the sensor and the positioning element can be up to 5 mm, whereby the nominal distance is 1 mm.

## Accessories

P1-RI-QR20

1593041

Positioning element for encoder RI-QR20, for Ø 6 mm shafts

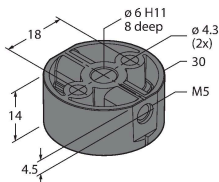

P2-RI-QR20

1593042

Positioning element for encoder RI-QR20, for Ø 6.35 mm shafts

