

TURCK

Your Global Automation Partner

Solenoid Driver IMX12-DO

Safety Manual



Contents

1	About this Document	5
2	Scope	5
3	Safety Integrity Level	5
4	Product Description	6
4.1	Safety function	6
4.2	Safe state	6
5	Safety-Planning	6
5.1	Architectural specifications	7
5.2	Assumptions	7
5.3	FMEDA results	7
5.4	Examples for using the results	7
5.4.1	Average probability of failure on demand (High Demand mode)	7
5.4.2	Average frequency of dangerous failure (Low Demand mode)	8
6	Safety Operating Instructions	8
6.1	General	8
6.2	Before operation	9
6.3	Operation	11
6.4	After operation	12
7	Appendix: Wiring Diagrams	12
7.1	IMX12-DO01-1U-1U	12
7.2	IMX12-DO01-2U-2U	13
8	Appendix: Terms and Abbreviations	13
9	Appendix: Proof Tests	14
10	Appendix: Document History	14
11	Appendix: Certificate	15



1 About this Document

This safety manual contains all information that is required to operate the device in functional safety systems. Read this manual carefully before using the device.

This document addresses only functional safety according IEC 61508. Other aspects, such as intrinsic safety, are not considered.

All instructions must be followed in order to assure functional safety.

Always make sure that this is the latest version of the safety manual at www.turck.com. The English version is considered the definitive document. Care was taken in the production of the translations of this document. If there is any uncertainty in its interpretation, refer to the English version of the safety manual or contact TURCK directly.

2 Scope

This safety manual is valid for the following devices.

ID	Product Name	Number of channels	Terminal Block Design	Power-Bridge
7580100	IMX12-DO01-1U-1U-PR/24VDC	1	screw clamps	yes
7580101	IMX12-DO01-1U-1U-0/24VDC	1	screw clamps	no
7580102	IMX12-DO01-1U-1U-PR/24VDC/CC	1	spring-type terminals	yes
7580103	IMX12-DO01-1U-1U-0/24VDC/CC	1	spring-type terminals	no
7580104	IMX12-DO01-2U-2U-PR/24VDC	2	screw clamps	yes
7580105	IMX12-DO01-2U-2U-0/24VDC	2	screw clamps	no
7580106	IMX12-DO01-2U-2U-PR/24VDC/CC	2	spring-type terminals	yes
7580107	IMX12-DO01-2U-2U-0/24VDC/CC	2	spring-type terminals	no

Power-Bridge is not safety-related.

3 Safety Integrity Level

The devices are rated to a SIL of

SIL2, SC3

4 Product Description

The Solenoid Drivers IMX12-DO are one or two channel devices and feature an intrinsically safe output with limited current and voltage. Thus making direct connection to loads in the hazardous area possible.

Output A1 is assigned to input E1, output A2 is assigned to E2.

Typical applications are the control of EX I pilot valves as well as the supply of displays and transmitters.

The following image shows the output characteristic:

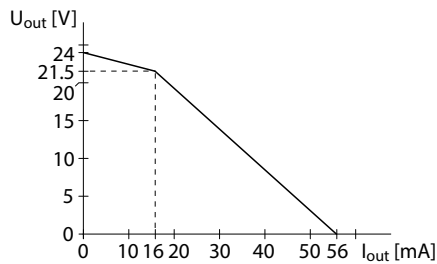

4.1 Safety function

If a Low signal is present at input [E1, E2], a voltage less than 2 VDC is present at the corresponding output [A1, A2] within maximum 40 ms.

The products can be used with a hardware fault tolerance $HFT = 0$, e.g. in a 1oo1 architecture up to SIL 2 and with a hardware fault tolerance $HFT = 1$, e.g. in a 1oo2 architecture up to SIL 3, dependent of the application.

The two channels are not used for the same safety function, e.g. to increase the hardware failure tolerance to achieve a higher SIL, as they contain common components.

The Power-Bridge is not part of the safety-function.

4.2 Safe state

In the safe state a voltage $< 2\text{ V}$ is present at the output [A1, A2].

5 Safety-Planning

This chapter provides information for planning a safety-related loop.

The device is not specified for a certain application. Make sure that the data provided in this chapter is valid for your target application.

Special application-specific factors may cause the premature wear of the device and must be taken into consideration when planning systems; take special measures to compensate for a lack of experience based values, e.g. through implementation of shorter test intervals.

The suitability for specific applications must be assessed by considering the particular overall safety-related system with regard to the requirements of IEC 61508.

Safety-planning must only be carried out by trained and qualified personnel.

In case of doubt contact TURCK directly.

5.1 Architectural specifications

Due to architectural considerations the following characteristics are specified:

Type	A
HFT	0

Experience has shown that the useful lifetime often lies within a range of 8 to 12 years. It can be significantly less if elements are operated near their specification limits. However, it can be extended by appropriate measures. For example, heavy temperature fluctuations could decrease the useful lifetime, as constant temperature below 40 °C could potentially increase the useful lifetime.

5.2 Assumptions

- Failure rates are constant for 10 years, wear out mechanisms are not included
- Propagation of failures is not relevant
- External power supply failure rates are not included
- All components that are not part of the safety function and cannot influence the safety function (feedback immune) are excluded.
- Only one input and one output are part of the safety function.

5.3 FMEDA results

The following safety characteristic are the results of the FMEDA.

λ_{SD}	λ_{SU}	λ_{DD}	λ_{DU}	No effect	SFF	DC
0 FIT	200 FIT	0 FIT	8 FIT	412 FIT	96 %	0 %

The stated Safe Failure Fraction (SFF) is for reference only. The complete subsystem will need to be evaluated to determine the overall SFF.

The failure rates used in this analysis are the basic failure rates from the Siemens standard SN 29500 based on the average ambient temperature of components of 40 °C.

“No effect” is a failure mode of a component that plays part in implementing the safety function but is neither a safe nor a dangerous failure. According to IEC 62061 it would be possible to classify the “No effect” failures as “Safe Undetected” failures. Not doing so represents the worst-case.

5.4 Examples for using the results

The following sections provide information about the probability of failures in high demand and low demand mode according to IEC 61508.

5.4.1 Average probability of failure on demand (High Demand mode)

The PFH values are based on a worst-case diagnostic test rate and a reaction time of 20 ms. The ratio of the diagnostic test rate to the demand rate shall equal or exceed 100.

PFH
8.20E-09 1/h

5.4.2 Average frequency of dangerous failure (Low Demand mode)

With the FMEDA results and the values specified in the following table, the average frequency of dangerous failure can be calculated:

T1	8760 h
MTTR	24 h
PFD_{avg}	
	3.91E-05

6 Safety Operating Instructions

6.1 General

- ▶ The device must be registered online: www.turck.com/SIL or with the supplied SIL registration card. This must be filled in with all required information first of all and sent to TURCK.
- ▶ The device must only be carried out, fitted, installed, operated, commissioned and maintained by trained and qualified personnel.
- ▶ The device is not specified for a certain application. Make sure that application-specific aspects are considered.
- ▶ Data from other documents, e.g. data sheets, is not valid for functional safety operation. Devices must be used in cabinets in an typical industrial field environment only. The following restrictions describe the operation and storage conditions:

- ▶ Ensure that the environment complies with the following ratings

Minimum ambient temperature	-25 °C
Maximum ambient temperature	70 °C
Minimum storage temperature	-40 °C
Maximum storage temperature	80 °C
Maximum air humidity	95 %
Minimum air pressure	80 kPa
Maximum air pressure	110 kPa

- ▶ The average temperature over a long period of time directly on the exterior sidewall of the housing must be maximum 40 °C.
 - The temperature on the exterior sidewall of the housing can deviate considerably from the temperature in the control cabinet.
 - The temperature on the exterior sidewall of the housing must be observed in a steady state.
 - In case the temperature on the exterior sidewall of the housing is higher, the failure rates from „5.3 FMEDA results“ on page 7 must be adjusted:
 - For a higher average temperature of 60 °C on the exterior sidewall of the housing, the failure rates are multiplied by an experience factor of 2.5.
- ▶ Ensure that sufficient heat dissipation is provided.
- ▶ Protect the device from radiated heat and severe temperature fluctuations.
- ▶ Protect the device from dust, dirt, moisture, shock, vibration, chemical stress, increased radiation and other environmental influences.
- ▶ Ensure a degree of protection of at least IP20 according to IEC 60529 at the mounting location.
- ▶ Ensure that the electromagnetic stress does not increase the requirements of IEC 61326-3.1.
- ▶ If there is a visible error, e. g. defective housing the device must not be used.

- ▶ During operation of the device, surface temperatures may occur that could lead to burns if touched.
- ▶ The device must not be repaired. If problems occur with regard to functional safety, TURCK must be notified immediately and the device must be returned immediately to:
TURCK GmbH
Witzlebenstraße 7
45472 Mülheim an der Ruhr
Germany

6.2 Before operation

- ▶ Fasten the device to a rail according EN 60715 (TH35) as follows:

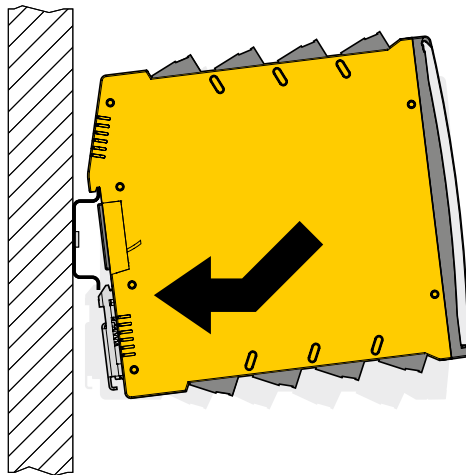

Fig. 1: Fasten the device

- ▶ Connect cables according to the wiring diagrams in „7 Appendix: Wiring Diagrams“ on page 12
- ▶ Use cables with Terminal cross section
 - rigid: 0.2 mm² to 2.5 mm² or
 - flexible 0.2 mm² to 2.5 mm²
- ▶ When wiring with stranded wires: Fix the wiring ends with ferrules.

Connection via screw terminals

- ▶ Insert the stripped cable ends (7 mm) in the guides of the cable glands.
- ▶ Fasten the screws with a screwdriver (max. tightening torque 0.5 Nm) to affix the cable ends.

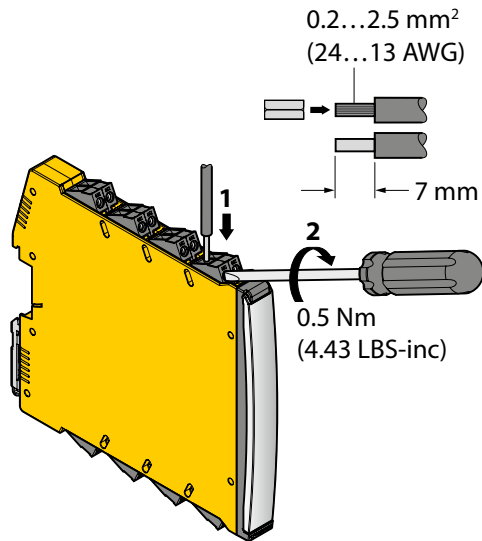

Fig. 2: Connection with screw terminals

Connection with spring-type terminals

- ▶ Push the opening lever with a suitable screwdriver.
- ▶ Insert the stripped cable ends (7 mm) in the guides of the spring-type terminals.
- ▶ Pull the screwdriver to fix the cable ends.

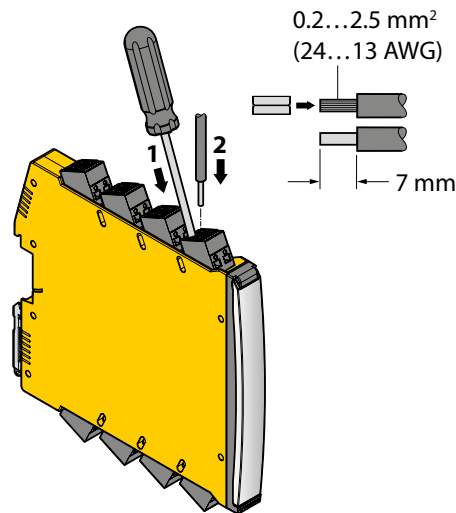

Fig. 3: Connection with spring-type terminals

- ▶ Make sure that only suitable equipment, e.g. sensors, are connected to the device (see „7 Appendix: Wiring Diagrams“ on page 12).
- ▶ Make sure that a suitable power supply with the following characteristic is used:

Minimum voltage	10 V
Maximum voltage	30 V
Minimum power	4 W

The proof test (see „9 Appendix: Proof Tests“ on page 14) shall be executed in order to check the requested function.

The device shall be locked against unintended operation/modification.

6.3 Operation

- ▶ If the device is used in low demand mode, proof tests shall be executed (see „9 Appendix: Proof Tests“ on page 14).
- ▶ Ensure that the plug connections and cables are always in good condition.
- ▶ The device must be replaced immediately if the terminals are faulty or the device has any visible faults.
- ▶ If cleaning is required, do not use any liquid or statically charging cleaning agent. Perform proof tests after each cleaning (see „9 Appendix: Proof Tests“ on page 14).

6.4 After operation

- ▶ Undo the terminal connection on the device.
- ▶ Remove the device from its rail fixing as shown in the figure:

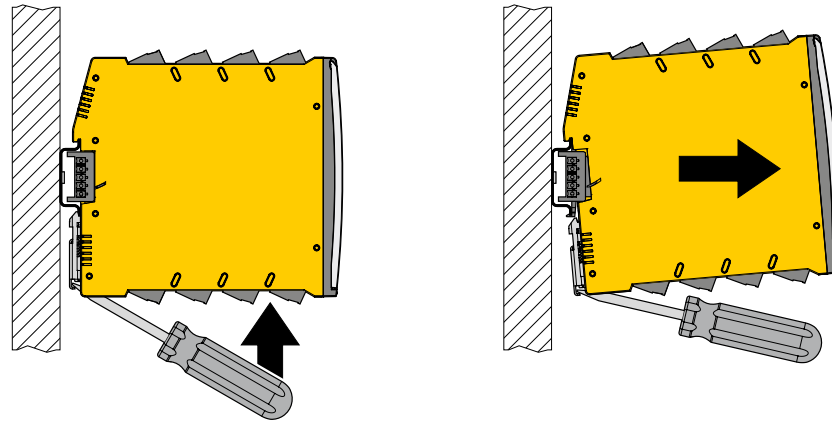

Fig. 4: Remove device

- ▶ Ensure the proper dispose of the device.

7 Appendix: Wiring Diagrams

The pin number assignment can be found at the front label.

7.1 IMX12-DO01-1U-1U

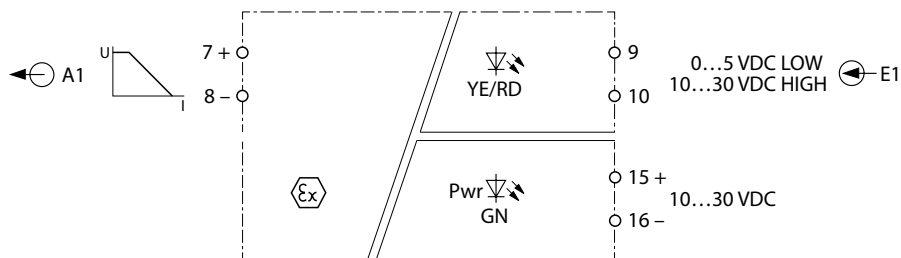

7.2 IMX12-DO01-2U-2U

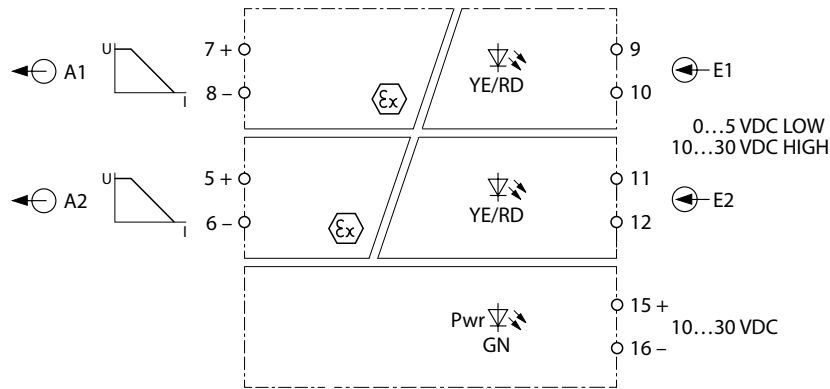

8 Appendix: Terms and Abbreviations

DC	Diagnostic Coverage
FIT	1 FIT is 1 failure per 10E09 hours
FMEDA	Failure Modes, Effects and Diagnostic Analysis
HFT	Hardware failure tolerance
λAU	Undetected Annunciation failure rate (per hour) Annunciation failures do not directly impact safety but impact the ability to detect a future fault (such as a fault in diagnostic circuit).
λDD	Detected dangerous failure rate (per hour)
λDU	Undetected dangerous failure rate (per hour)
λSD	Detected safe failure rate (per hour)
λSU	Undetected safe failure rate (per hour)
MTTR	Mean time to restoration (hour)
PFD_{avg}	Average probability of failure on demand
PFH	Average frequency of dangerous failure
SFF	Safe Failure Fraction
SIL	Safety Integrity Level
T1	Proof test interval (hour)
Type A	"Non-complex" element (all failure modes are well defined); for details see 7.4.4.1.2 of IEC 61508-2
Type B	"Complex" element (using micro controllers or programmable logic); for details see 7.4.4.1.3 of IEC 61508-2

9 Appendix: Proof Tests

According to section 7.4.5.2 f) of IEC 61508-2 proof tests shall be undertaken to reveal dangerous faults which are undetected by diagnostic tests. This means that it is necessary to specify how dangerous undetected faults which have been noted during the FMEDA can be detected during proof testing.

Ensure that the proof test is only carried out by qualified personnel.

A suggested proof test consists of the following steps:

Step	Action
1.	Bypass the safety function and take appropriate action to avoid a false trip.
2.	Provide appropriate input-/control signals to the interface modules and verify the expected signal input/output conditions for the interfaces.
3.	Verify if internal fault detection is working in case it is activated.
4.	Provide appropriate input-/control signals to the interface modules and verify that the safety function is carried out correctly.
5.	Remove the bypass and otherwise restore normal operation.

This test will detect 99 % of possible dangerous undetected failures.

Once the test has been completed, document and archive the results.

10 Appendix: Document History

Document Version	Date	Modifications
1.0	2015-10-15	Initial version
2.0	2016-08-15	<ul style="list-style-type: none"> - Online registration - Useful lifetime updated - 7 mm cable ends - Terms updated
3.0	2018-07-06	<ul style="list-style-type: none"> - headings high-/low-demand updated - note for 61326-3-1 modified: exceed (not increase) - note for safety function added: Power-Bridge is not part
4.0	2020-04-01	<ul style="list-style-type: none"> - Ambient temperature specified more precisely - Factor 2.5 for 60 °C ambient temperature added - Application SN 29500 specified
5.0	2026-01-29	<ul style="list-style-type: none"> - SC3 added - Description added: capability of use in a 1oo2 architecture up to SIL 3 with a hardware fault tolerance HFT = 1, depending on the applicatio - SIL card removed

11 Appendix: Certificate

The certificate can be found on the internet at www.turck.com.

TURCK

Your Global Automation Partner



Over 30 subsidiaries and
60 representations worldwide!

D201477 | 2026/01



www.turck.com