

TURCK

Your Global Automation Partner

IM(X)12-FI01-1SF-1R Frequency Transducer

Safety Manual

Contents

1	About this Document	5
2	Scope	5
3	Safety Integrity Level	5
4	Product Description	6
4.1	Safety function	7
4.2	Safety accuracy	7
4.3	Safe state	7
4.4	Alarm state	7
5	Safety Planning	8
5.1	Architectural specifications	8
5.2	Assumptions	8
5.3	FMEDA results	9
5.4	Examples for using the results	9
5.4.1	Probability of dangerous failure per hour (High Demand Mode)	9
5.4.2	Average probability of dangerous failure on demand (Low Demand Mode)	10
6	Operation Instructions	11
6.1	General	11
6.2	Before operation	12
6.3	Parameterization	14
6.3.1	Parameters	14
6.3.2	Parameter check	17
6.4	Operation	18
6.5	After operation	19
7	Appendix: Connection and Wiring Diagrams	20
8	Appendix: Terms and Abbreviations	21
9	Appendix: Proof Test	22
10	Appendix: Document History	22



1 About this Document

This safety manual contains all information that is required to operate the device in functional safety systems. Read this manual carefully before using the device.

This document addresses only functional safety according IEC 61508. Other, e.g. intrinsic safety, is not considered.

All instructions must be followed in order to assure functional safety.

Always make sure that this is the latest version of the safety manual at www.turck.com. The English version is considered the definitive document. Care was taken in the production of the translations of this document. If there is any uncertainty in its interpretation. Always refer to the English version of the safety manual or contact TURCK directly.

2 Scope

This safety manual is valid for the following devices:

ID	Product Name	Number of Channels	Terminal Block Design	Power-Bridge-Connection	Intrinsic Safety
7580200	IMX12-FI01-1SF-1R-PR/24VDC	1	screw clamps	yes	yes
7580201	IMX12-FI01-1SF-1R-0/24VDC	1	screw clamps	no	yes
7580202	IMX12-FI01-1SF-1R-PR/24VDC/CC	1	spring-type terminals	yes	yes
7580203	IMX12-FI01-1SF-1R-0/24VDC /CC	1	spring-type terminals	no	yes
7580220	IM12-FI01-1SF-1R-PR/24VDC	1	screw clamps	yes	no
7580221	IM12-FI01-1SF-1R-0/24VDC	1	screw clamps	no	no
7580222	IM12-FI01-1SF-1R-PR/24VDC/CC	1	spring-type terminals	yes	no
7580223	IM12-FI01-1SF-1R-0/24VDC /CC	1	spring-type terminals	no	no

In the following chapters the devices are divided

- IMX12-FI01-1SF-1R
- IM12-FI01-1SF-1R

3 Safety Integrity Level

The devices are rated to a SIL of

SIL 2

4 Product Description

In the following chapter the individual variants are described:
All information provided in this chapter is not part of safety function.

IMX12-FI01-1SF-1R	Single-channel rotation speed monitor/frequency converter Frequency range 0...20 kHz. With intrinsically safe ex protection. Reaction time digital output is 50 ms Parameterization via switches Inputs – NAMUR-Sensors according to EN 60947-5-6, line monitoring (up to 20 kHz) – potential free contacts (up to 10 kHz) Outputs – Common alarm output (MOSFET), potential free – Relay output SPDT – monitoring overshoot/undershoot and window limits – working direction adjustable – reaction time digital output < 50 ms
IM12-FI01-1SF-1R	Single-channel rotation speed monitor/frequency converter Frequency range 0...20 kHz. Reaction time digital output is 50 ms Parameterization via switches Inputs – NAMUR-Sensors according to EN 60947-5-6, line monitoring (up to 20kHz) – PNP/NPN-sensors – potential free contacts (up to 10 kHz) – external signal source – 0-signal 0...3 V – 1-signal 5...30 V Outputs – Common alarm output (MOSFET), potential free – Relay output SPDT – monitoring overshoot/undershoot and window limits – working direction adjustable – reaction time digital output < 50 ms

4.1 Safety function

IMX12-FI01-1SF-1R IM12-FI01-1SF-1R	The measured or monitored value at input [E1] are transmitted to the output [A1D] according to parameterization and within the local process safety time observing the permissible safety accuracy.
---	---

Local process safety time is:

- $f_{in} > 1,124 \text{ Hz}$: 1 s
- $f_{in} < 1,124 \text{ Hz}$: $1/f+110 \text{ ms}$

The power bridge is not part of safety-function.

The LED are not part of the safety-function.

The common alarm output is not part of safety function.

Two devices must not be used for the safety-function, e. g. to increase the hardware fault tolerance to achieve a higher SIL.

A 1oo2 architecture does not achieve a SIL3.

The safety function is executed 2 s after power-on.

The frequency limits for the inputs are:

- NAMUR-Sensors according to EN 60947-5-6, line monitoring , 1 μHz ... 10 kHz, pulse pause ratio > 50 μs
- PNP/NPN-sensors, 1 μHz ... to 10 kHz, pulse pause ratio > 50 μs
- potential free contacts, 1 μHz ... 10 kHz, pulse pause ratio > 50 μs
- external signal source, 1 μHz ... to 10 kHz, pulse pause ratio > 50 μs
 - 0-signal 0...3 V
 - 1-signal 5...30 V

The local process safety time is the periodical internal diagnostic check (900 ms) + reaction time.

4.2 Safety accuracy

The safety accuracy Δ_{total} depends on the variant and its configuration.

In order to evaluate the safety accuracy for an individual configuration the following information is required:

- $\Delta_{[Ex]}$ is < 0.1 % of input frequency

Assignment [E] to [A]	Δ_{total}
[E1] → [A1D]	$\Delta_{total} = \Delta_{[E1]}$

4.3 Safe state

IMX12-FI01-1SF-1R IM12-FI01-1SF-1R	The safe state is defined as the output is de-energized (A1D).
---	--

4.4 Alarm state

Internal diagnostics are provided in order to detect random hardware failures that result in a failure of the function. If a failure is detected the device goes into the alarm state. The time between the occurrence of the failure and the time to achieve the alarm state is less than 1 s. The device remains in alarm state as long as the failure persists, at least for 1 s.

IMX12-FI01-1SF-1R IM12-FI01-1SF-1R	The alarm state is defined as the output is de-energized (A1D).
---	---

5 Safety Planning

This chapter provides information for planning a safety-related loop.

The device is not specified for a certain application. Make sure that the data provided in this chapter is valid for your target application.

Special application-specific factors may cause the premature wear of the device and must be taken into consideration when planning systems; take special measures to compensate for a lack of experience based values, e.g. through implementation of shorter test intervals.

The suitability for specific applications must be assessed by considering the particular overall safety-related system with regard to the requirements of IEC 61508.

Safety-planning must only be carried out by trained and qualified personnel.

If there is any doubt contact TURCK directly.

5.1 Architectural specifications

Due to architectural considerations the following characteristics are specified:

Type	B
HFT	0

Experience has shown that the useful lifetime often lies within a range of 8 to 12 years. It can be significantly less if elements are operated near their specification limits. However, it can be extended by appropriate measures. For example, heavy temperature fluctuations could potentially decrease the useful lifetime, as constant temperature below 40 °C could potentially increase the useful lifetime.

The relay [A1D] must be protected against an over current ($\cos \phi = 1, I = 2 \text{ A AC}$).

For the relay outputs the useful lifetime is 8 to 12 years or 30.000 switching cycles.

5.2 Assumptions

- Failure rates are constant for 10 years, wear out mechanisms are not included
- Propagation of failures are not relevant
- External power supply failure rates are not included
- All components that are not part of the safety function and cannot influence the safety function (feedback immune) are excluded.
- Only one input and one output are part of the safety function

5.3 FMEDA results

The following safety characteristic are results of FMEDA.

Digital output	λ_{SD}	λ_{SU}	λ_{DD}	λ_{DU}	λ_{AU}	No effect	DC [λ_{DD}/λ_D]	SFF
IMX12-FI01-1SF-1R	0 FIT	196.5 FIT	249.5 FIT	38 FIT	0 FIT	409.4 FIT	86,78 %	92.15 %
IM12-FI01-1SF-1R	0 FIT	196.5 FIT	249.5 FIT	38 FIT	0 FIT	409.4 FIT	86,78 %	92.15 %

The stated Safe Failure Fraction (SFF) is for reference only. The complete subsystem will need to be evaluated to determine the overall SFF. The failure rates used in this analysis are the basic failure rates from the Siemens standard SN 29500 based on the average ambient temperature of components of 40 °C.

“No effect” is a failure mode of a component that plays part in implementing the safety function but is neither a safe nor a dangerous failure. According to IEC 62061, it would be possible to classify the “No effect” failures as “Safe Undetected” failures. Not doing so represents the worst-case.

5.4 Examples for using the results

5.4.1 Probability of dangerous failure per hour (High Demand Mode)

The sum of the diagnostic test interval and the time to achieve the specified safe/alarm state is less than 1 s. The ratio of the diagnostic test rate to the demand rate shall equal or exceed 100.

Digital Output	PFH
IMX12-FI01-1SF-1R	39.99E-09 1/h
IM12-FI01-1SF-1R	39.99E-09 1/h

5.4.2 Average probability of dangerous failure on demand (Low Demand Mode)

With the FMEDA results and the values specified in the following table the average frequency of dangerous failure can be calculated as an example:

T1	8760 h
MTTR	24 h
Digital output	PFDavg
IMX12-FI01-1SF-1R	1.73E-04
IM12-FI01-1SF-1R	1.73E-04

6 Operation Instructions

6.1 General

- ▶ The device must be registered online: <http://www.turck.com/SIL>
- ▶ The device must only be carried out, fitted, installed, operated, commissioned and maintained by trained and qualified personnel.
- ▶ The device is not specified for a certain application. Make sure that application-specific aspects are considered.
- ▶ Data from other documents, e.g. data sheets, is not valid for functional safety operation. Devices must be used in cabinets in an typical industrial field environment only. The following restrictions describe the operation and storage conditions:

- ▶ Ensure that the environment complies with the following ratings:

Minimum ambient temperature	-25 °C
Maximum ambient temperature	70 °C
Minimum storage temperature	-40 °C
Maximum storage temperature	80 °C
Maximum air humidity	95 %
Minimum air pressure	80 kPa
Maximum air pressure	110 kPa

- ▶ The average temperature over a long period of time directly on the exterior sidewall of the housing must be maximum 40 °C.
 - The temperature on the exterior sidewall of the housing can deviate considerably from the temperature in the control cabinet.
 - The temperature on the exterior sidewall of the housing must be observed in a steady state.
 - In case the temperature on the exterior sidewall of the housing is higher, the failure rates from „5.3 FMEDA results“ on page 9 must be adjusted:
For a higher average temperature of 60 °C on the exterior sidewall of the housing, the failure rates are multiplied by an experience factor of 2.5.
- ▶ Ensure that sufficient heat dissipation is provided.
- ▶ Protect the device from radiated heat and severe temperature fluctuations.
- ▶ Protect the device from dust, dirt, moisture, shock, vibration, chemical stress, increased radiation and other environmental influences.
- ▶ Ensure a degree of protection of at least IP20 according to IEC 60529 at the mounting location.
- ▶ Ensure that the electromagnetic stress does not exceed the requirements of IEC 61326-3.1.
- ▶ If there is a visible error, e.g. defective housing the device must not be used.
- ▶ During operation of the device, surface temperatures may occur that could lead to burns if touched.
- ▶ The device must not be repaired. If problems occur with regard to functional safety, TURCK must be notified immediately and the device must be returned immediately to:

TURCK GmbH
Witzlebenstraße 7
45472 Mülheim
Germany

- ▶ The device must not stay in safe state longer than 24 h. If the cause of entering the safe state was not corrected the device must be replaced.

6.2 Before operation

- ▶ Fasten the device to a rail according to EN 60715 (TH35) as follows:

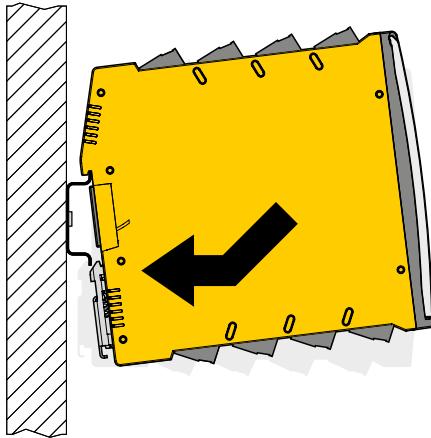

Fig. 1: Fasten the device

- ▶ Connect cables according to the wiring diagrams in „Appendix: Connection and Wiring Diagrams“ on page 20.
- ▶ Use cables with terminal cross section
 - rigid: 0.2 mm² to 2.5 mm² or
 - flexible 0.2 mm² to 2.5 mm²
- ▶ When wiring with stranded wires: Fix the wiring ends with ferrules.

Connection via screw terminals

- ▶ Insert the stripped cable ends (7 mm) in the guides of the cable glands.
- ▶ Fasten the screws with a screwdriver (max. tightening torque 0.5 Nm)

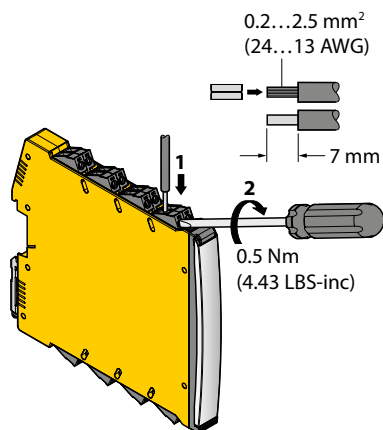

Fig. 2: Connection with screw terminals

Connection with spring-type terminals

- ▶ Push the opening lever with a suitable screwdriver.
- ▶ Insert the stripped cable ends (7 mm) in the guides of the spring-type terminals.
- ▶ Pull the screwdriver to fix the cable ends.

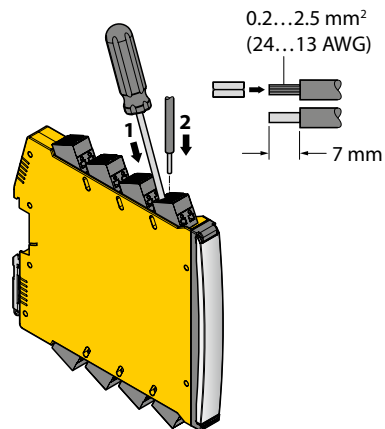

Fig. 3: Connection with spring-type terminals

- ▶ Make sure that only suitable equipment, e.g. sensors, are connected to the device (see „Appendix: Connection and Wiring Diagrams“).
- ▶ Make sure that a suitable power supply with the following characteristic is used:

Minimum voltage	10 VDC
Maximum voltage	30 VDC
Minimum Power	4 W

6.3 Parameterization

The user must select the parameters suitable for its safety application.

6.3.1 Parameters

The parameters are set using the switches on the housing side.

This is done with the help of a screwdriver.

If the teach button is pressed for 3 s, the parameters are adopted.

Sensor type

Selection	Description
NAMUR	NAMUR sensor according to EN 60947-5-6 – 0-signal: sensor not actuated – 1-signal: sensor actuated
Switch	Potential free contact – 0-signal: switch open – 1-signal: switch closed
Voltage signal	Voltage signal: – 0-signal 0...3 V – 1-signal 5...30 V
3-wire PNP	3-wire sensor (positive, negative, positive) – 0-signal: sensor not actuated (0 V) – 1-signal: sensor actuated (12 V)
3-wire NPN	3-wire sensor (negative, positive, negative) – 0-signal: sensor not actuated (12 V) – 1-signal: sensor actuated (0 V)

Line monitoring (for NAMUR-sensors):

Selection	Description
Off	Line monitoring is switched off
Wire break and short circuit	Line monitoring short circuit and wire break

Parameters:

Switch	Parameter	State	Comment
S1	Line monitoring	OFF/ON	OFF/ON
S2	Relay mode	2P/4P	(2-point)/(4-point)
S3	2P: Under/Overspeed	Under/Over	Under-/Overspeed
S4	Relay direction	Ninv/inv	(not inverted)/(inverted)
S5	Function Relay Loc	OFF/ON	OFF/ON
S6	Locked switching	LocOn/Locoff	Locked On/Locked Off
S7	SUD Input	[E2]/[E3]	Input [E2]/input [E2]
S8	SUD mode	Dyn/Stat	Dynamic/Static

Rotary switches:

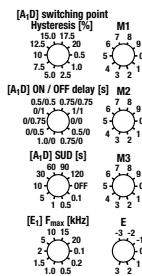

The function on/off delay is not part of the safety function and must be set to 0 s.

[A1D] switching point: $G = (M1 * 100 + M2 * 10 + M3 * 1) * 10^E \text{ Hz}$

Example 1: 321 mHz: M1 = 3, M2 = 2, M3 = 1; E = -3

Example 2: 50.6 kHz: M1 = 5, M2 = 0, M3 = 6; E = 2

Hysteresis: $H = \{0.5, 1.0, 2.5, 5.0, 7.5, 10.0, 12.5, 15.0, 17.5, 20.0\} [\%]$

Switching mode

Selection	Description
2-point	<p>In 2-point mode a lower switch point BotOff and an upper switch point TopOn can be defined in the permissible measuring range.</p> <p>The switch points must fulfill the following condition: $\text{BotOff} \leq \text{TopOn}$</p> <p>The hysteresis can be 0.</p> <p>The switching behavior depends on parameter "inversion".</p> <p>The following figure shows the switching behavior when inversion is deactivated:</p>

Fig. 4: 2-point mode

4-point	<p>In 4-point mode a window with a lower and upper hysteresis is formed.</p> <p>The switch points must fulfill the following condition: $\text{BotOff} \leq \text{BotOn} < \text{TopOn} \leq \text{TopOff}$</p> <p>The hysteresis can be 0.</p> <p>The switching behavior depends on parameter "inversion".</p> <p>The following figure shows the switching behavior when inversion is deactivated:</p>
---------	--

Fig. 5: 4-point mode

BotOn/BotOff/TopOn/TopOff

These parameters represent the switching threshold for 2-point and 4-point switching modes. The switching thresholds must not exceed the measuring range.

These parameters represent the switching threshold for 2-point switching modes:

Selection	Mode	Switching point	Range
BotOff	Under/NInv	G	0...f _{max}
TopOn	Under/NInv	$G * (1 + H[\%]/100 \%)$	< f _{max}
BotOn	Over/NInv	$G * (1 - H[\%]/100 \%)$	0...f _{max}
TopOff	Over/NInv	G	< f _{max}
BotOn	Under/Inv	G	0...f _{max}
TopOff	Under/Inv	$G * (1 + H[\%]/100 \%)$	< f _{max}
BotOff	Over/Inv	$G * (1 - H[\%]/100 \%)$	0...f _{max}
TopOn	Over/Inv	G	< f _{max}

These parameters represent the switching threshold for 4-point switching modes:

Selection	Mode	Switching point	Range
BotOff	NInv	$G * (1 - 1.2 * H[\%]/100\%)$	> 0
BotOn	NInv	$G * (1 - H[\%]/100\%)$	
TopOn	NInv	$G * (1 + H[\%]/100\%)$	
TopOff	NInv	$G * (1 + 1.2 * H[\%]/100\%)$	0...f _{max}
BotOn	Inv	$G * (1 - 1.2 * H[\%]/100\%)$	> 0
BotOff	Inv	$G * (1 - H[\%]/100\%)$	
TopOff	Inv	$G * (1 + H[\%]/100\%)$	
TopOn	Inv	$G * (1 + 1.2 * H[\%]/100\%)$	< f _{max}

Locking function

This parameter depends on the physical state of the relay. Parameter "Inversion" is regarded.

Selection	Description
Switched on	The relay switches on according to the measured value and selected configuration. It stays permanently locked on. The locked state is left after power on reset or detection of a failure.
Switched off	The relay switches off according to the measured value and selected configuration. It stays permanently locked off. The locked state is left after power on reset.

Switching on/off delay

The value of this parameter specifies the switch on/off delay after detection of of switch on/off condition.

Values between 0.05...75 s are possible.

Selection	Description	(Ex, NEx)
On delay	The value of this parameter specifies the switch on delay after detection of switch on condition.	0.0, 0.5, 0.75, 1.0 s
Off delay	The value of this parameter specifies the switch off delay after detection of switch on condition.	0.0, 0.5, 0.75, 1.0 s

Inversion

Selection	Description
Activated	This function enables the inversion of the switching state (instead of off, on and vice versa).
Deactivated	If the inversion function is disabled, the switching state is transferred to the digital output A1D without inversion according to the parameter setting.

Hysteresis

The hysteresis is adjustable between 0.5...20 %.

Start up delay (SUD)

This function must not be used for safety applications (choose SUD = 0 s)

The SUD is adjustable between off... 120 s.

Selection	Description	(Ex, NEx)
SUD (Start up delay)	SUD causes a delayed switching behavior of [A1D] after detection of a SUD condition. 0 s means SUD is switched off.	0.0, 0.1, 0.5, 1.0, 5, 10, 30, 60, 90, 120 s

Fmax

Fmax the maximum frequency of the used sensor and adjustable between 0.1...20 kHz.

If the measured input frequency is higher than the adjusted value, the device falls into the safe state.

Config

If the parameters are set, push config button between 2 and 6 seconds.

In this way the device takes over the set values.

If the button is pushed less than 2 seconds or more then 6 seconds, the new parameter set will not be taken over and the "old" parameter set remains.

The successful take over will be signalized via LED (red LED is flashing 4 times).

As long as the config button is pushed, the device remains in the safe state.

You must not push config button during operation!

6.3.2 Parameter check

- The proof test (see „Appendix: Proof Test“ on page 22) shall be executed in order to check the requested function and parameterization.
- The tests shall be executed even if the device was not parameterized.
- Within the proof tests each relevant parameter shall be checked for correct function.
- The device shall be locked against unintended operation/modification.
- The device must not parameterized during operation.
- The proof test shall be documented.

6.4 Operation

- If the device is used in low demand mode, proof tests shall be executed periodically according to T1 (see „Appendix: Proof Test“ on page 22).
- Ensure that the plug connections and cables are always in good condition.
- The device must be replaced immediately if the terminals are faulty or the device has any visible faults.
- If cleaning is required, do not use any liquid or statically charging cleaning agent. Perform proof tests after each cleaning (see „Appendix: Proof Test“ on page 22).
- The device must be replaced before remaining longer than 24 h within the safe state due to an internal failure
- The proof test (see „Appendix: Proof Test“ on page 22) shall be executed each time after installation and parameterization in order to check the requested function.
- The DIP switches shall not be modified during operation. The device shall be locked against unintended operation/modification.

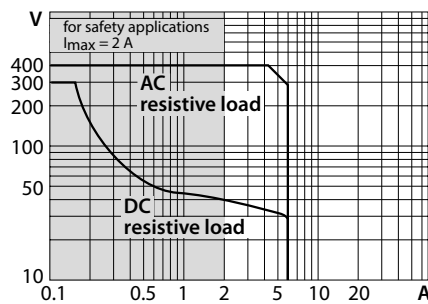

Fig. 6: Output relay load curve

The connection of a deactivated input is unnecessary.

6.5 After operation

- ▶ Undo the terminal connection on the device.
- ▶ Remove the device from its rail fixing as shown in the figure:

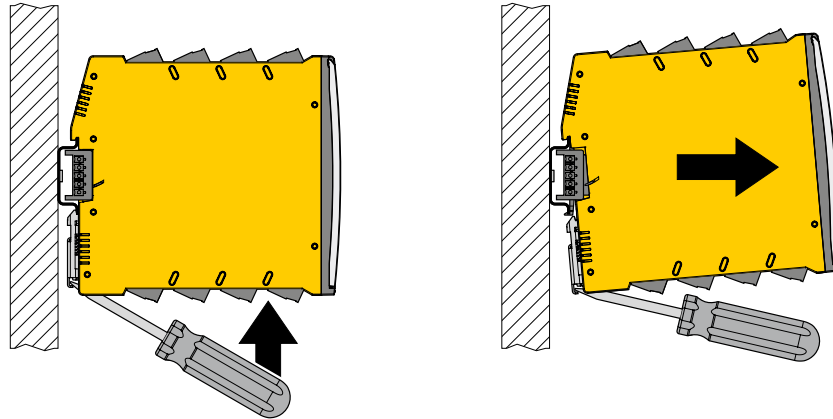

Fig. 7: Remove device

- ▶ Ensure the dispose of the device.

7 Appendix: Connection and Wiring Diagrams

The pin number assignment can be found at the front label.

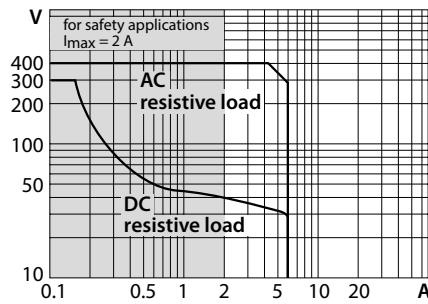
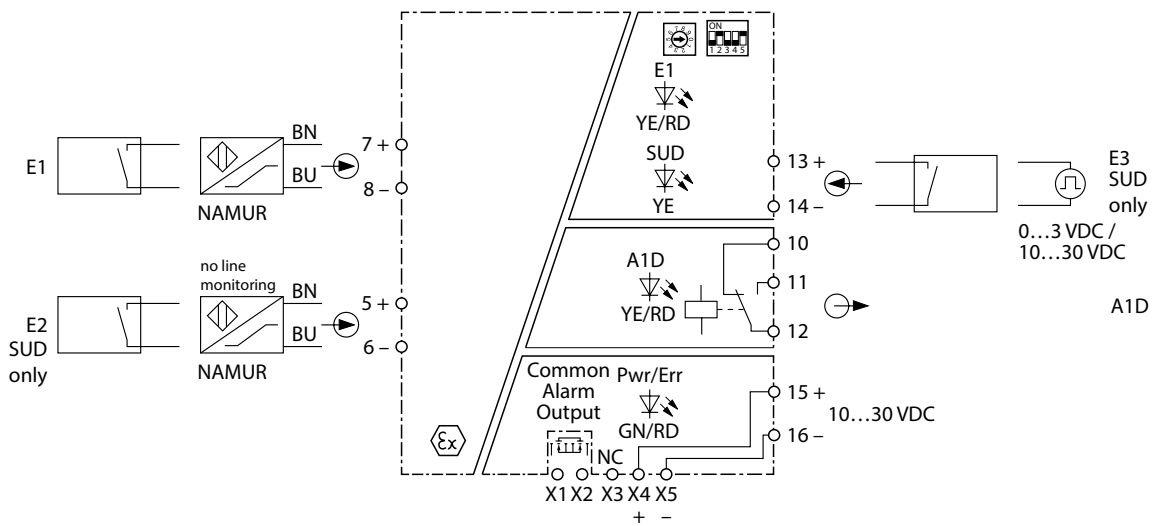

Fig. 8: Output relay load curve

The load curve of the relay [A1D] must be observed. The relay must be protected against overcurrent.

IMX12-FI01-1SF-1R



IM12-FI01-1SF-1R

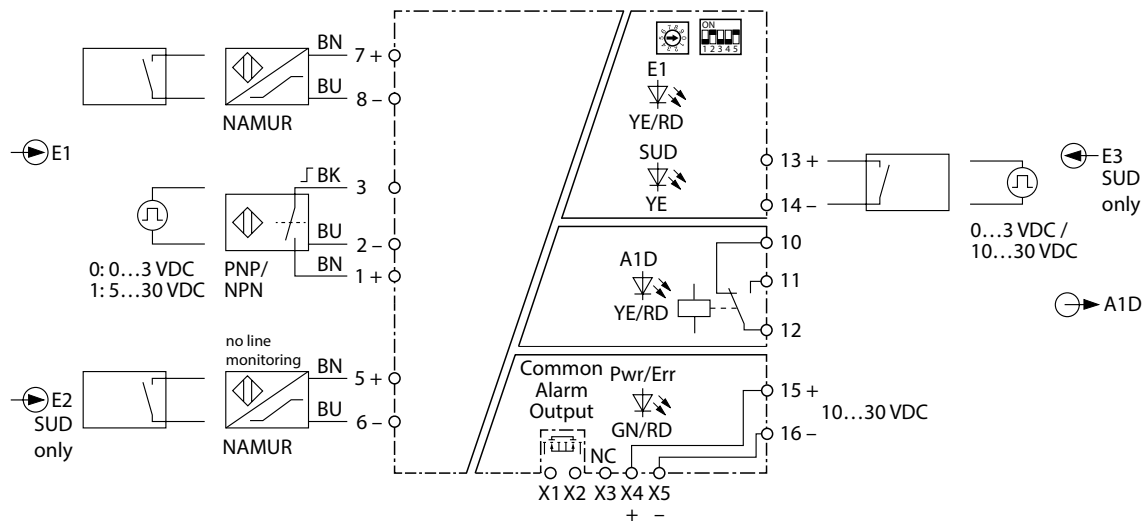

8 Appendix: Terms and Abbreviations

DC	Diagnostic Coverage
FIT	1 FIT is 1 failure per E09 hours
FMEDA	Failure Modes, Effects and Diagnostic Analysis
HFT	Hardware failure tolerance
λ_{AU}	Undetected Annunciation failure rate (per hour) Annunciation failures do not directly impact safety but impact the ability to detect a future fault (such as a fault in diagnostic circuit).
λ_{DD}	Detected dangerous failure rate (per hour)
λ_{DU}	Undetected dangerous failure rate (per hour)
λ_{SD}	Detected safe failure rate (per hour)
λ_{SU}	Undetected safe failure rate (per hour)
MTTR	Mean time to restoration (hour)
PFD_{avg}	Average probability of dangerous failure on demand
PFH	Probability of dangerous failure per hour
SFF	Safe Failure Fraction
SIL	Safety Integrity Level
T1	Proof test interval (hour)
Type A	"Non-complex" element (all failure modes are well defined); for details see 7.4.4.1.2 of IEC 61508-2
Type B	"Complex" element (using micro controllers or programmable logic); for details see 7.4.4.1.3 of IEC 61508-2

9 Appendix: Proof Test

Proof tests shall be undertaken to reveal dangerous faults that are undetected by diagnostic tests. This means that it is necessary to specify how dangerous undetected faults which have been previously noted during the FMEDA can be detected during proof testing.

Ensure that the proof test is only carried out by qualified personnel.

A suggested proof test consists of the following steps:

Step	Action
1.	Bypass the safety functions and take appropriate action to avoid a false trip.
2.	Provide appropriate input-/control signals to the interface modules and verify the expected signal input/output conditions for the interfaces.
3.	Verify if internal fault detection is working in case it is activated.
4.	Provide appropriate input-/control signals to the interface modules and verify that the safety function is carried out correctly.
5.	Remove the bypass and otherwise restore normal operation.

This test will detect 95.5 % of possible dangerous undetected failures.

Once the test has been completed, document and archive the results.

10 Appendix: Document History

Document version	Date	Modifications
1.0	2020-04-07	Initial version
2.0	2026-01-29	SIL card removed

TURCK

Your Global Automation Partner

Over 30 subsidiaries and
60 representations worldwide!

100017761 | 2026/01



www.turck.com