

**TURCK**

Your Global Automation Partner

# IMX12-FI... | IM12-FI... Frequency Transducer

Safety Manual



# Contents

<b>1</b>	<b>About this document</b>	<b>5</b>
<b>2</b>	<b>Scope</b>	<b>5</b>
<b>3</b>	<b>Safety Integrity Level</b>	<b>5</b>
<b>4</b>	<b>Product description</b>	<b>6</b>
4.1	Safety function	7
4.2	Safety accuracy	7
4.3	Safe state	8
4.4	Alarm state	8
<b>5</b>	<b>Safety planning</b>	<b>9</b>
5.1	Architectural specifications	9
5.2	Assumptions	9
5.3	FMEDA results	10
5.4	Examples for using the results	10
5.4.1	Probability of dangerous failure per hour (High Demand Mode)	10
5.4.2	Average Probability of dangerous failure on demand (Low Demand Mode)	11
<b>6</b>	<b>Operation instructions</b>	<b>12</b>
6.1	General	12
6.2	Before operation	13
6.3	Parameterization	16
6.3.1	Preparation	16
6.3.2	Parameters	16
6.3.3	Parameter-Check	24
6.4	Operation	25
6.5	After operation	25
<b>7</b>	<b>Appendix: Connection and wiring diagrams</b>	<b>26</b>
<b>8</b>	<b>Appendix: Terms and abbreviations</b>	<b>28</b>
<b>9</b>	<b>Appendix: Proof test</b>	<b>29</b>
<b>10</b>	<b>Appendix: Document history</b>	<b>29</b>



# 1 About this document

This safety manual contains all information that is required to operate the device in functional safety systems. Read this manual carefully before using the device.

This document addresses only functional safety according IEC 61508. Other, e.g. intrinsic safety, is not considered.

All instructions must be followed in order to assure functional safety.

Always make sure that this is the latest version of the safety manual at [www.turck.com](http://www.turck.com). The English version is considered the definitive document. Care was taken in the production of the translations of this document. If there is any uncertainty in its interpretation. Always refer to the English version of the safety manual or contact TURCK directly.

# 2 Scope

This safety manual is valid for the following devices:

ID	Product Name	Number of Channels	Terminal Block Design	Power-Bridge-Connection
7580204	IMX12-FI01-1SF-111R-CPR/24VDC	1	screw clamps	yes
7580205	IMX12-FI01-1SF-111R-C0/24VDC	1	screw clamps	no
7580206	IMX12-FI01-1SF-111R-CPR/24VDC/CC	1	spring-type terminals	yes
7580207	IMX12-FI01-1SF-111R-C0/24VDC/CC	1	spring-type terminals	no
7580208	IMX12-FI01-2SF-2I-CPR/24VDC	2	screw clamps	yes
7580209	IMX12-FI01-2SF-2I-C0/24VDC	2	screw clamps	no
7580210	IMX12-FI01-2SF-2I-CPR/24VDC/CC	2	spring-type terminals	yes
7580211	IMX12-FI01-2SF-2I-C0/24VDC/CC	2	spring-type terminals	no
7580224	IM12-FI01-1SF-111R-CPR/24VDC	1	screw clamps	yes
7580225	IM12-FI01-1SF-111R-C0/24VDC	1	screw clamps	no
7580226	IM12-FI01-1SF-111R-CPR/24VDC/CC	1	spring-type terminals	yes
7580227	IM12-FI01-1SF-111R-C0/24VDC/CC	1	spring-type terminals	no
7580228	IM12-FI01-2SF-2I-CPR/24VDC	2	screw clamps	yes
7580229	IM12-FI01-2SF-2I-C0/24VDC	2	screw clamps	no
7580230	IM12-FI01-2SF-2I-CPR/24VDC/CC	2	spring-type terminals	yes
7580231	IM12-FI01-2SF-2I-C0/24VDC/CC	2	spring-type terminals	no

In the following chapters the devices are divided

- IMX12-FI01-1SF-111R
- IM12-FI01-1SF-111R
- IMX12-FI01-2SF-2I
- IM12-FI01-2SF-2I

# 3 Safety Integrity Level

The devices are rated to a SIL of

**SIL 2**

## 4 Product description

In the following chapter the individual variants are described:

All information provided in this chapter is not part of safety function.

- IMX12-FI01-1SF-111R** Single-channel rotation speed monitor/frequency converter/pulse counter.  
 Frequency range 0...20 kHz.  
 With intrinsically safe ex protection.  
 Reaction time digital output is 50 ms, for the analog output 100 ms.  
 Inputs  
 – NAMUR-Sensors according to EN 60947-5-6, line monitoring (up to 20 kHz)  
 – potential free contacts (up to 10 kHz)  
 – Adjustable via PC interface (PC-connect)  
 Outputs  
 – Current output source/sink 0/4...20 mA (linear to input frequency or proportional to counter reading)  
 – Common alarm output (MOSFET), potential free  
 Relay output (NO)  
 – monitoring overshoot/undershoot and window limits  
 – working direction adjustable
- IM12-FI01-1SF-111R** Single-channel rotation speed monitor/frequency converter/pulse counter.  
 Frequency range 0...20 kHz.  
 Reaction time digital output is 50ms, for the analog output 100 ms.  
 Inputs:  
 – NAMUR-Sensors according to EN 60947-5-6, line monitoring (up to 20 kHz)  
 – PNP/NPN-sensors  
 – potential free contacts (up to 10 kHz)  
 – external signal source (0-signal 0...3 V, 1-signal 5...30 V)  
 – Adjustable via PC interface (PC-connect)  
 Outputs  
 – Current output source/sink 0/4...20 mA (linear to input frequency or proportional to counter reading)  
 – Common alarm output (MOSFET), potential free  
 Relay output (NO)  
 – monitoring overshoot/undershoot and window limits  
 – working direction adjustable
- IMX12-FI01-2SF-2I** Dual-channel rotation speed monitor/frequency converter/pulse counter  
 Frequency range 0...20 kHz  
 With intrinsically safe ex protection  
 For the analog output 100 ms.  
 Inputs:  
 – with ex protection intrinsically safe  
 – NAMUR-Sensors according to EN 60947-5-6, line monitoring (up to 20 kHz)  
 – potential free contacts (up to 10 kHz)  
 – Adjustable via PC interface (PC-connect)  
 Outputs  
 – Current output source/sink 0/4...20 mA (linear to input frequency or proportional to counter reading)  
 – Common alarm output (MOSFET), potential free
- IM12-FI01-2SF-2I** Dual-channel rotation speed monitor/frequency converter/pulse counter  
 Frequency range 0...20 kHz  
 For the analog output 100 ms.  
 Inputs:  
 – NAMUR-Sensors according to EN 60947-5-6, line monitoring (up to 20 kHz)  
 – PNP/NPN-sensors  
 – potential free contacts (up to 10 kHz)  
 – external signal source (0-signal 0...3 V, 1-signal 5...30 V)  
 – Adjustable via PC interface (PC-connect)  
 Outputs  
 – Current output source/sink 0/4...20 mA (linear to input frequency or proportional to counter reading)  
 – Common alarm output (MOSFET), potential free

## 4.1 Safety function

<b>IMX12-FI01-1SF-111R</b> <b>IM12-FI01-1SF-111R</b>	The measured or monitored values at input [E1, E2] are transmitted to the output [A1A, A1D] according to parameterization and within the local process safety time observing the permissible safety accuracy.
<b>IMX12-FI01-1SF-111R</b> <b>IM12-FI01-1SF-111R</b>	If the configured rotation direction is applied to [E1, E2], this information shall de-energize the output [A1D] according to parameterization and within the local process safety time observing the permissible safety accuracy.
<b>IMX12-FI01-2SF-2I</b> <b>IM12-FI01-2SF-2I</b>	The measured values at input [E1, E2] are transmitted to the output [A1A, A2A] according to parameterization and within the local process safety time observing the permissible safety accuracy.

Local process safety time is:

- $f_{in} > 1,124 \text{ Hz}$  1 s
- $f_{in} < 1,124 \text{ Hz}$   $1/f + 110 \text{ ms}$

The configuration possibilities include difference measurement.

The power bridge is not part of safety-function.

The LED are not part of the safety-function.

The common alarm output is not part of safety function.

Two devices must not be used for the same safety-function, e.g. to increase the hardware fault tolerance to achieve a higher SIL.

A 1oo2 architecture does not achieve a SIL3.

The two channels on the 2-channel device must not be used for the same safety function, e.g. to increase the hardware fault tolerance to achieve a higher SIL.

The safety function is executed 2 s after power-on.

The frequency limits for the inputs are:

- NAMUR-Sensors according to EN 60947-5-6, line monitoring , 1  $\mu\text{Hz}$  ... 10 kHz, pulse pause ratio > 50  $\mu\text{s}$
- PNP/NPN-sensors, 1  $\mu\text{Hz}$  ... to 10 kHz, pulse pause ratio > 50  $\mu\text{s}$
- potential free contacts, 1  $\mu\text{Hz}$  ... 10 kHz, pulse pause ratio > 50  $\mu\text{s}$
- external signal source, 1  $\mu\text{Hz}$  ... to 10 kHz, pulse pause ratio > 50  $\mu\text{s}$ 
  - 0-signal 0...3 V
  - 1-signal 5...30 V

The current output range for safety application is 4...20 mA (according to NE43).

The local process safety time is the periodical internal diagnostic check (900 ms) + reaction time.

## 4.2 Safety accuracy

The safety accuracy  $\Delta_{total}$  depends on the variant and its configuration.

In order to evaluate the safety accuracy for an individual configuration the following information is required:

- $\Delta_{[Ex]}$  is < 0,1 % of input frequency
  - $\Delta_{[Ax]} = 100 \mu\text{A} / (16 \text{ mA} / (| \text{"measuring range start"} - \text{"measuring range end"} |))$
- $\Delta_{[Ax]}$  refers to the particular output  $\Delta_{[A1A]}$  or  $\Delta_{[A2A]}$ .

IMX12-FI01-1SF-111R / IM12-FI01-1SF-111R

The safety accuracy  $\Delta_{total}$  depends on the parameter "[Ex] assigned to [Ax]":

Assignment [E] → [A]	$\Delta_{total}$
[E1] → [A1A]	$\Delta_{total} = \Delta_{[E1]} + \Delta_{[Ax]}$
[E1] → [A1D]	$\Delta_{total} = \Delta_{[E1]}$
[E1 - E2] → [Ax]	$\Delta_{[E1]} + \Delta_{[E2]} + \Delta_{[Ax]}$
[E2 - E1] → [Ax]	$\Delta_{[E1]} + \Delta_{[E2]} + \Delta_{[Ax]}$

IMX12-FI01-2SF-2I / IM12-FI01-2SF-2I

The safety accuracy  $\Delta_{total}$  depends on the parameter “[Ex] assigned to [Ax]”:

Assignment [E] to [A]	$\Delta_{total}$
[E1] → [Ax]	$\Delta_{[E1]} + \Delta_{[Ax]}$
[E2] → [Ax]	$\Delta_{[E2]} + \Delta_{[Ax]}$
[E1 - E2] → [Ax] [E2 - E1] → [Ax]	$\Delta_{[E1]} + \Delta_{[E2]} + \Delta_{[Ax]}$

4.3 Safe state

IMX12-FI01-1SF-111R IM12-FI01-1SF-111R	The safe state is defined as the output is de-energized (A1D).
IMX12-FI01-2SF-2I IM12-FI01-2SF-2I IMX12-FI01-1SF-111R IM12-FI01-1SF-111R	The safe state is defined as the output reaching the user defined threshold value (AxA).

4.4 Alarm state

Internal diagnostics are provided in order to detect random hardware failures that result in a failure of the function. If a failure is detected the device goes into the alarm state. The time between the occurrence of the failure and the time to achieve the alarm state is less than 1s. The device remains in alarm state as long as the failure persists, at least for 1s.

IMX12-FI01-1SF-111R IM12-FI01-1SF-111R	The alarm state is defined as the output is de-energized (A1D).
IMX12-FI01-2SF-2I IM12-FI01-2SF-2I IMX12-FI01-1SF-111R IM12-FI01-1SF-111R	The alarm state is defined as the output is less than 3.6 mA or greater than 21 mA (AxA).

## 5 Safety planning

This chapter provides information for planning a safety-related loop.

The device is not specified for a certain application. Make sure that the data provided in this chapter is valid for your target application.

Special application-specific factors may cause the premature wear of the device and must be taken into consideration when planning systems; take special measures to compensate for a lack of experience based values, e.g. through implementation of shorter test intervals.

The suitability for specific applications must be assessed by considering the particular overall safety-related system with regard to the requirements of IEC 61508.

Safety-planning must only be carried out by trained and qualified personnel.

In case of doubt contact TURCK directly.

### 5.1 Architectural specifications

Due to architectural considerations the following characteristics are specified:

Type	B
HFT	0

Experience has shown that the useful lifetime often lies within a range of 8 to 12 years. It can be significantly less if elements are operated near their specification limits. However, it can be extended by appropriate measures. For example, heavy temperature fluctuations could potentially decrease the useful lifetime, as constant temperature below 40 °C could potentially increase the useful lifetime.

For the relay outputs ( $\cos \phi = 1, I = 2 \text{ A AC}$ ) the useful lifetimes is 8 to 12 years or 30.000 switching cycles. The relay must be protected against an over current.

### 5.2 Assumptions

- Failure rates are constant for 10 years, wear out mechanisms are not included
- Propagation of failures are not relevant
- External power supply failure rates are not included
- All components that are not part of the safety function and cannot influence the safety function (feedback immune) are excluded.
- Only one input and one output are part of the safety function

### 5.3 FMEDA results

The following safety characteristic are results of FMEDA.

Digital output	$\lambda_{SD}$	$\lambda_{SU}$	$\lambda_{DD}$	$\lambda_{DU}$	$\lambda_{AU}$	Noeffect	DC	SFF
IMX12-FI01-1SF-111R	0	275	301	59	40	40	83%	90%
IM12-FI01-1SF-111R	0	275	301	59	40	40	83%	90%
Analog output	$\lambda_{SD}$	$\lambda_{SU}$	$\lambda_{DD}$	$\lambda_{DU}$	$\lambda_{AU}$	Noeffect	DC	SFF
IMX12-FI01-2SF-2I	0	0	625	41	47	503	93%	93%
IM12-FI01-2SF-2I	0	0	625	41	47	503	93%	93%
IMX12-FI01-1SF-111R	0	0	625	41	47	503	93%	93%
IM12-FI01-1SF-111R	0	0	625	41	47	503	93%	93%

The stated Safe Failure Fraction (SFF) is for reference only. The complete subsystem will need to be evaluated to determine the overall SFF. The failure rates used in this analysis are the basic failure rates from the Siemens standard SN 29500 based on the average ambient temperature of components of 40 °C.

“No effect” is a failure mode of a component that plays part in implementing the safety function but is neither a safe nor a dangerous failure. According to IEC 62061, it would be possible to classify the “No effect” failures as “Safe Undetected” failures. Not doing so represents the worst-case.

For analog outputs a  $\lambda_{DD}$  failure is defined as a failure that is dangerous but is detected by internal diagnostics and causes the output the output signal to go to the maximum output current (> 21 mA) or minimum output current (< 3,6 mA).

### 5.4 Examples for using the results

#### 5.4.1 Probability of dangerous failure per hour (High Demand Mode)

The sum of the diagnostic test interval and the time to achieve the specified safe/alarm state is less than 1s. The ratio of the diagnostic test rate to the demand rate shall equal or exceed 100.

Digital Output	PFH
IMX12-FI01-1SF-111R	5.9E-08 1/h
IM12-FI01-1SF-111R	5.9E-08 1/h

Analog Output	PFH
IMX12-FI01-2SF-2I	4.1E-08 1/h
IM12-FI01-2SF-2I	4.1E-08 1/h
IMX12-FI01-1SF-111R	4.1E-08 1/h
IM12-FI01-1SF-111R	4.1E-08 1/h

5.4.2 Average Probability of dangerous failure on demand (Low Demand Mode)

With the FMEDA results and the values specified in the following table the average frequency of dangerous failure can be calculated as an example:

<b>T1</b>	8760 h
<b>MTTR</b>	24 h

<b>Digital output</b>	<b>PFDavg</b>
IMX12-FI01-1SF-1I1R	3.12E-04
IM12-FI01-1SF-1I1R	3.12E-04

<b>Analog output</b>	<b>PFDavg</b>
IMX12-FI01-2SF-2I	2.29E-04
IM12-FI01-2SF-2I	2.29E-04
IMX12-FI01-1SF-1I1R	2.29E-04
IM12-FI01-1SF-1I1R	2.29E-04

## 6 Operation instructions

### 6.1 General

- ▶ The application program in the safety logic solver is configured according to NAMUR NE43 to detect under-range and over-range failures of the 4...20 mA output signal, and does not automatically trip on these failures. Therefore, these failures have been classified as dangerous detected failures.
- ▶ The device must not stay in safe state longer than 24 h. If the cause of entering the safe state was not corrected the device must be replaced.
- ▶ The user must detect currents < 3.6 mA and > 21 mA and maintain the safe state of the system.
- ▶ The device must be registered online: <http://www.turck.com/SIL>
- ▶ The device must only be carried out, fitted, installed, operated, commissioned and maintained by trained and qualified personnel.
- ▶ The device is not specified for a certain application. Make sure that application-specific aspects are considered.
- ▶ Data from other documents, e.g. data sheets, is not valid for functional safety operation. Devices must be used in cabinets in an typical industrial field environment only. The following restrictions describe the operation and storage conditions:

- ▶ Ensure that the environment complies with the following ratings:

Minimum ambient temperature	-25 °C
Maximum ambient temperature	70 °C
Minimum storage temperature	-40 °C
Maximum storage temperature	80 °C
Maximum air humidity	95 %
Minimum air pressure	80 kPa
Maximum air pressure	110 kPa

- ▶ The average temperature over a long period of time directly on the exterior sidewall of the housing must be maximum 40 °C.
  - The temperature on the exterior sidewall of the housing can deviate considerably from the temperature in the control cabinet.
  - The temperature on the exterior sidewall of the housing must be observed in a steady state.
  - In case the temperature on the exterior sidewall of the housing is higher, the failure rates from „5.3 FMEDA results“ on page 10 must be adjusted:  
For a higher average temperature of 60 °C on the exterior sidewall of the housing, the failure rates are multiplied by an experience factor of 2.5.
- ▶ Ensure that sufficient heat dissipation is provided.
- ▶ Protect the device from radiated heat and severe temperature fluctuations.
- ▶ Protect the device from dust, dirt, moisture, shock, vibration, chemical stress, increased radiation and other environmental influences.
- ▶ Ensure a degree of protection of at least IP20 according to IEC 60529 at the mounting location.
- ▶ Ensure that the electromagnetic stress does not exceed the requirements of IEC 61326-3.1.
- ▶ If there is a visible error, e.g. defective housing the device must not be used.
- ▶ During operation of the device, surface temperatures may occur that could lead to burns if touched.
- ▶ The device must not be repaired. If problems occur with regard to functional safety, TURCK must be notified immediately and the device must be returned immediately to:  
TURCK GmbH  
Witzlebenstraße 7  
45472 Mülheim  
Germany

## 6.2 Before operation

- ▶ Fasten the device to a rail according EN 60715 (TH35) as follows:

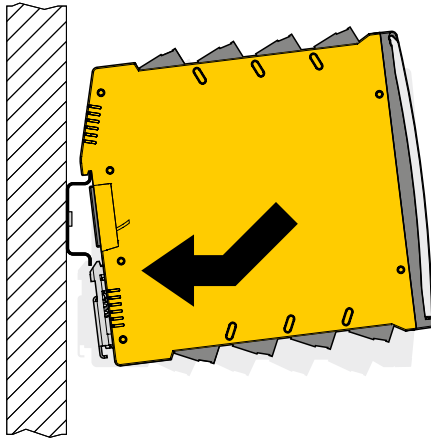

Fig. 1: Fasten the device

- ▶ Connect cables according to the wiring diagrams in „Appendix: Connection and Wiring Diagrams“.
- ▶ Use cables with Terminal cross section
  - rigid: 0.2 mm<sup>2</sup> to 2.5 mm<sup>2</sup> or
  - flexible 0.2 mm<sup>2</sup> to 2.5 mm<sup>2</sup>
- ▶ When wiring with stranded wires: Fix the wiring ends with ferrules.

### Connection via screw terminals

- ▶ Insert the stripped cable ends (7 mm) in the guides of the cable glands.
- ▶ Fasten the screws with a screwdriver (max. tightening torque 0.5 Nm)

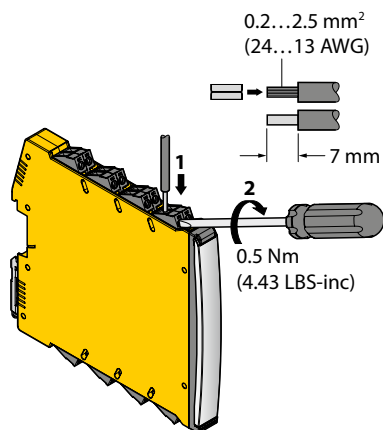

Fig. 2: Connection with screw terminals

## Connection with spring-type terminals

- ▶ Push the opening lever with a suitable screwdriver.
- ▶ Insert the stripped cable ends (7 mm) in the guides of the spring-type terminals.
- ▶ Pull the screwdriver to fix the cable ends

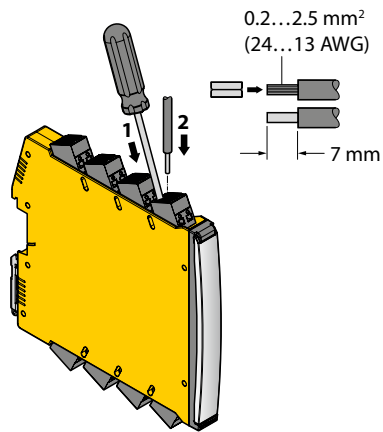

Fig. 3: Connection with spring-type terminals

- ▶ Make sure that only suitable equipment, e.g. sensors, are connected to the device (see „Appendix: Connection and Wiring Diagrams“).
- ▶ Make sure that a suitable power supply with the following characteristic is used:

Minimum voltage	10 VDC
Maximum voltage	30 VDC
Minimum Power	4 W

Rotation direction detection

For rotation directions detection two sensors are needed. The sensors must be connected to [E1] and [E2]. The detection element must be shaped so that both sensors detect the detection element for at least 1 ms.

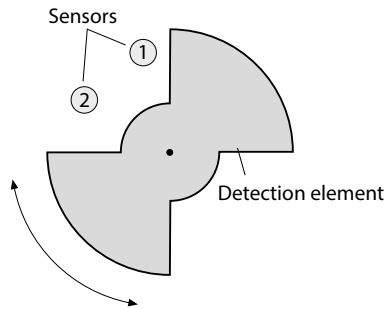

Fig. 4: Detection element

Depending on the rotation direction there will be the following input signals:

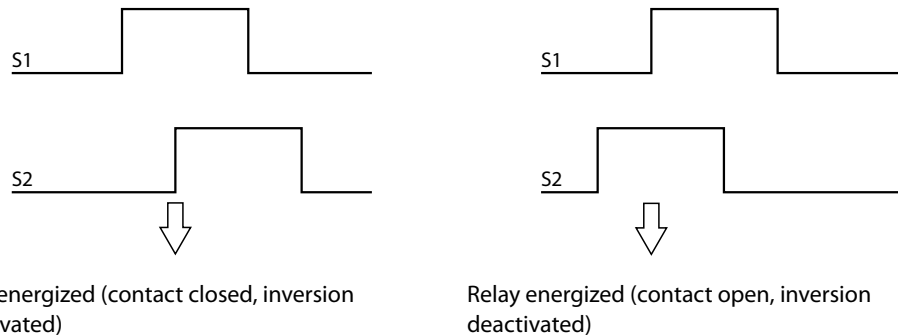

Fig. 5: Input signals rotation direction

Sensor S1 is to connected to [E1] and Sensor S2 is to connected to [E2]. If sensor S1 detects a rising edge before sensor S2 detects a rising edge, the direction is to the left.

If sensor S1 detects a rising edge after sensor S2 detects a rising edge, the direction is to the right.

The following times must be obeyed:

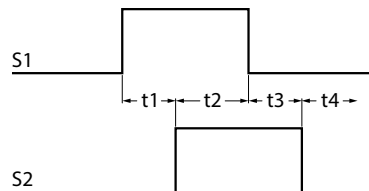

Fig. 6: Time relation rotation direction

- $t_1 \geq 0,5 \text{ ms}$
- $t_2 \geq 1 \text{ ms}$
- $t_3 \geq 0,5 \text{ ms}$
- $t_4 \geq 0,5 \text{ ms}$
- $f_{\text{max}} = 1 / (t_1 + t_2 + t_3 + t_4) = 400 \text{ Hz}$ .

## 6.3 Parameterization

### 6.3.1 Preparation

For parameterization the following parts are required in addition to a PC with a suitable operating system:

Part name	Article number	Description
USB-2-IOL-002	6825482	IO-Link master 1.1 with integrated USB port for connection of IMX-device and PC
IOL-COM/3M	7525110	IO-Link communication cable

The following software is required. The software can be downloaded at [www.turck.com](http://www.turck.com).

Name	Description
PACTware	FDT frame application
USB-2-IOL-0002 DTM	Device Type Manager for IO-Link master 1.1
IODD Interpreter	The IODD interpreter is used to implement IODDs in FDT frame applications
Device specific IODD	The IO Device Description contains information about the devices` identity, parameters and process data.

Setup according to the manuals in order to connect and parameterize the IMX device.

### 6.3.2 Parameters

The user must select the parameters suitable for its safety application.

#### Input

The following figure illustrates the dependence of the parameters. Other parameters are required depending on the previously selected parameters. Selection options for parameters not located on a route marked with arrows are irrelevant.

- IMX12-FI01-1SF-111R
- IMX12-FI01-2SF-2I

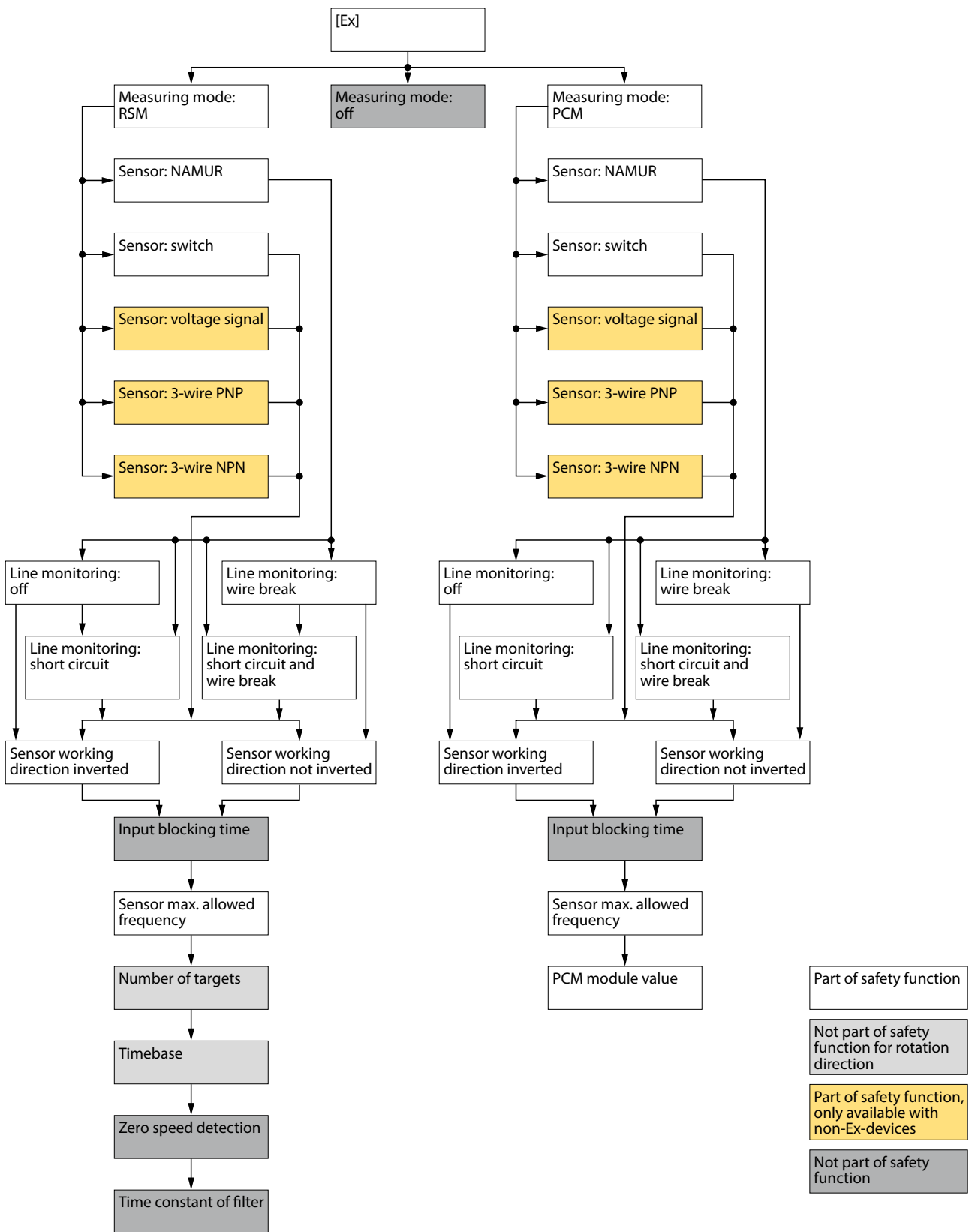

Fig. 7: Measurement conversion, dependency of input parameter

**Measuring Mode:**

Input channels [Ex] which are part of a safety function, must not be switched off.

Selection	Description
RSM	Rotation speed monitoring
PCM	Pulse counter mode
Off	Input is switched off

**Sensor Type:**

Selection	Description
NAMUR	NAMUR sensor according to EN 60947-5-6 0-signal: sensor not actuated 1-signal: sensor actuated
Switch	Potential free contact 0-signal: switch open 1-signal: switch closed
Voltage signal	Voltage signal: 0-signal 0...3 V 1-signal 5...30 V
3-wire PNP	3-wire sensor (positive, negative, positive) 0-signal: sensor not actuated (0 V) 1-signal: sensor actuated (12 V)
3-wire NPN	3-wire sensor (negative, positive, negative) 0-signal: sensor not actuated (12 V) 1-signal: sensor actuated (0 V)

**Line monitoring (for NAMUR-Sensors):**

Selection	Description
off	Line monitoring is switched off
wire break	Line monitoring wire break
short circuit	Line monitoring short circuit
wire break and short circuit	Line monitoring short circuit

**Additional Parameter**

Selection	Description
Working direction	When this Parameter is defined, the device calculates based on the falling edge or rising edge of the input frequency (in mode RSM) or increments the actual count (in mode PCM)
F0	Zero speed detection: If the speed falls below the value set here, the input frequency will be output as zero. This values must be 0 for safety application
Value for fmax of sensor	If a higher frequency than a parameterized fmax of the sensor is detected, the outputs will be set in the safe state or alarm state until a frequency is detected between 0...fmax or a POR(Power off reset) is made
NoTar	Number of detection element: Number of elements which the sensor detects per revolution of a shaft. The masured speed is divided by number of detected elements

Selection	Description
Tb	Time basis: Standard setting: 1 = Hz. If another unit is required, enter the respective conversion factor. The value 60 applies for the conversion from Hz to min <sup>-1</sup> (rpm). The measured rotational speed in Hz is multiplied with the factor (Tb). All of the following switching value settings are to be performed with the unit set here
Tc	Time constant of the filter in seconds to avoid superimposed interference frequencies. This values must be 0 for safety application
Td	Input inhibit time in seconds: After a pulse from a sensor, the sensor input will not be scanned for the set time (0...99.9 s). For example, this may suppress interference from bound and slow impulse trains. Exact knowledge of the input pulse train is required for setting. This values must be 0 for safety application
PCM	The PCM modulo value is the max value if the actual count. PCM +1 set the actual count to 0. The max value of PCM modulo is $1 \times 10^9$
SUD	Start up delay for: IMX12-FI01-1SF-111R and IM12-FI01-1SF-111R short circuit (terminals 11 and 12) Pulse (field side) – 0-signal 0...3 V – 1-signal 5...30 V Pulse (PLC-side) – 0-signal 0...3.5 V – 1-signal 10...30 V IM12-FI01-2SF-2I Pulse (field side) – 0-signal 0...3 V – 1-signal 5...30 V

## Analog Output

- IMX12-FI01-1SF-111R
- IMX12-FI01-1SF-111R
- IMX12-FI01-2SF-2I
- IMX12-FI01-2SF-2I

The following figure illustrates the dependence of the parameters. Other parameters are required depending on the previously selected parameters. Selection options for parameters not located on a route marked with arrows are not relevant.

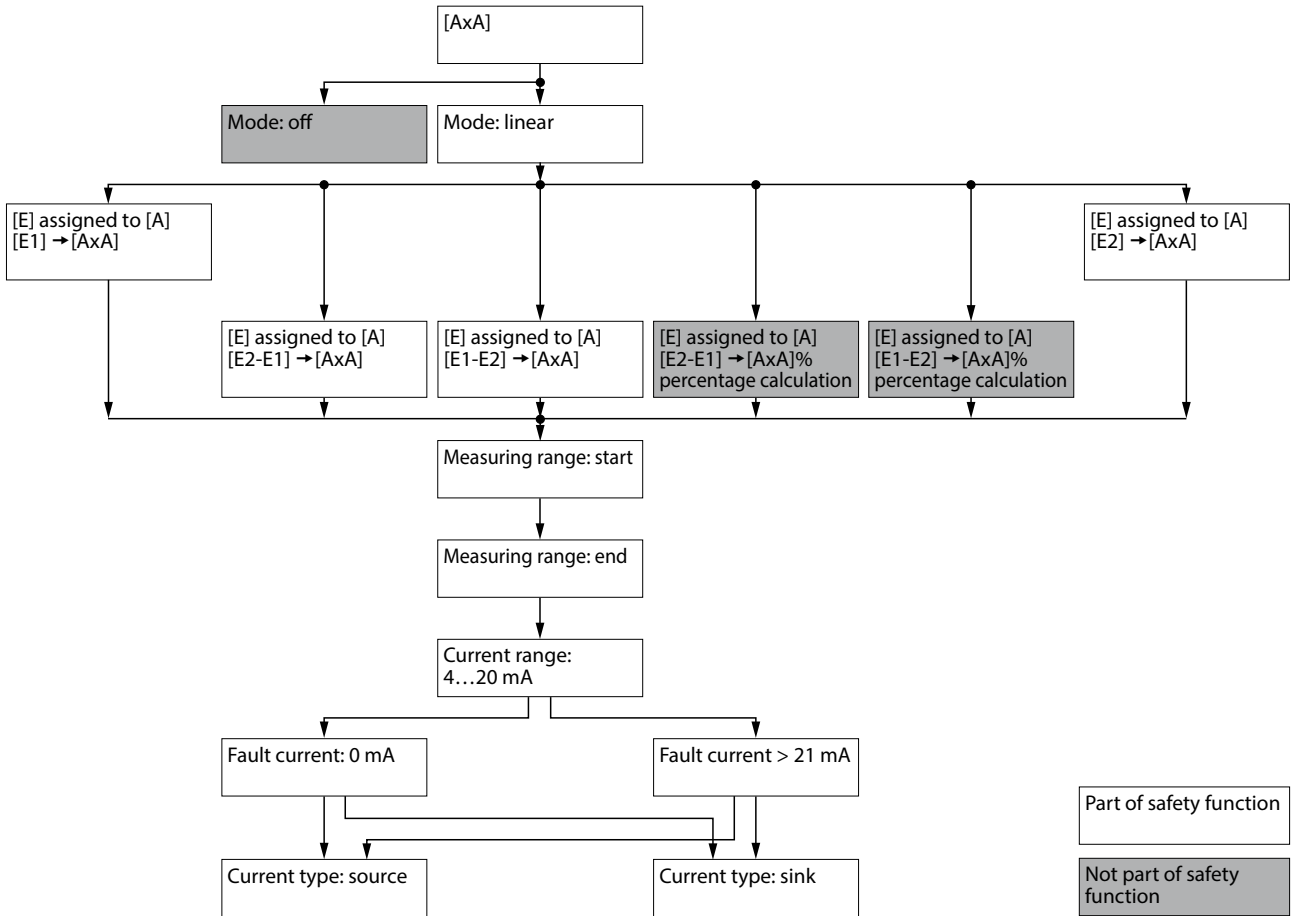

Fig. 8: Measurement conversion, dependency of output parameter (analog)

**[Ex] assigned to [AxA]**

Selection	Description
[E1] → [A1A]	The input [E1] is assigned to output [A1A].
[E1] → [A2A]	The input [E1] is assigned to output [A2A].
[E2] → [A1A]	The input [E2] is assigned to output [A1A].
[E2] → [A2A]	The input [E2] is assigned to output [A2A].
[E1 - E2] → [A1A]	The difference [E1 - E2] is assigned to output [A1A].
[E1 - E2] → [A2A]	The difference [E1 - E2] is assigned to output [A2A].
[E2 - E1] → [A1A]	The difference [E2 - E1] is assigned to output [A1A].
[E2 - E1] → [A2A]	The difference [E2 - E1] is assigned to output [A2A].

Output channels [AxA] which are part of a safety function, must not be switched off.

**Current Range**

Selection	Description
4...20 mA	The current output [AxA] operates in the range 4...20 mA (Live Zero).

**Current type**

Selection	Description
source	The current output operates as active source.
sink	The current output operates as passive sink.

**Measuring Range Start/End**

This parameter defines the start/end value of the measuring range of the analog output. The measuring range start/end must not exceed the measuring range. The span between measuring range start and measuring range end must be equal or higher than the minimum measuring span.

**Fault Current**

The fault current is adjustable to 0 or 21 mA.

### Digital output

- IMX12-FI01-1SF-111R
- IM12-FI01-1SF-111R

The following figure illustrates the dependence of the parameters. Other parameters are required depending on the previously selected parameters. Selection options for parameters not located on a route marked with arrows are not relevant.

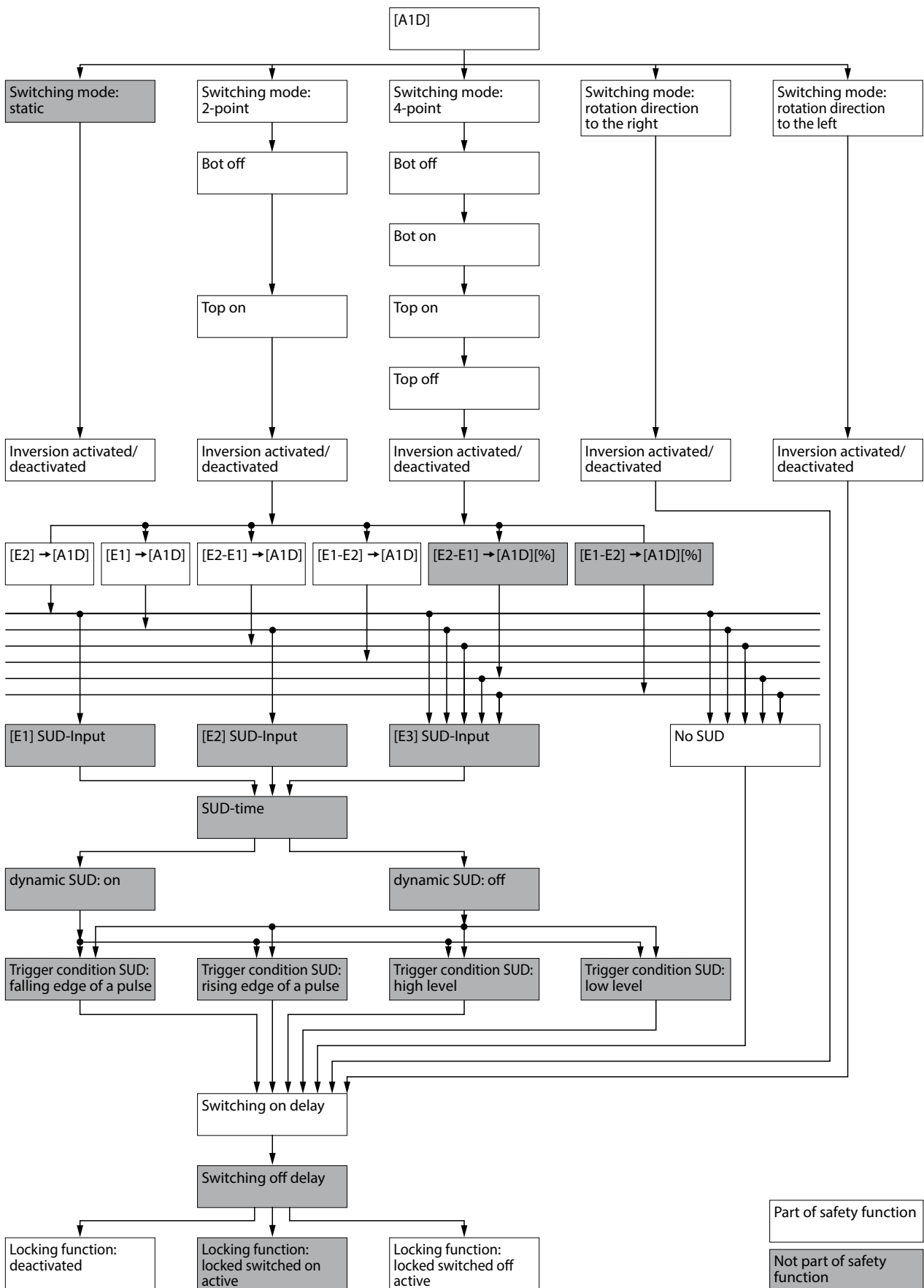

Fig. 9: Measurement conversion, dependency of output parameter (digital)

**[E<sub>x</sub>] assigned to [A<sub>1</sub>D]**

Selection	Description
[E1] → [A1D]	The input [E1] is assigned to output [A1D].
[E1 - E2] → [A1D]	The difference [E1 - E2] is assigned to output [A1D].
[E2 - E1] → [A1D]	The difference [E2 - E1] is assigned to output [A1D].

Output channels [AxD] which are part of a safety function must not be switched off.

**Switching Mode**

Selection	Description
2-point	In 2-point mode a lower switch point BotOff and an upper switch point TopOn can be defined in the permissible measuring range. The switch points must fulfill the following condition: $BotOff \leq TopOn$ The hysteresis can be 0. The switching behavior depends on parameter "inversion". The following figure shows the switching behavior when inversion is deactivated::

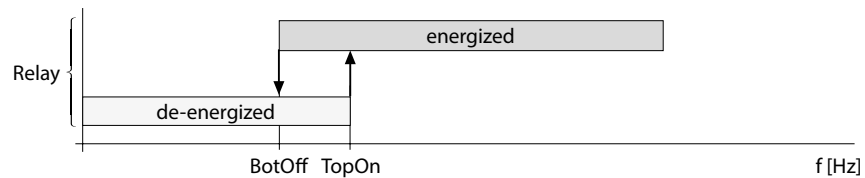

Fig. 10: 2-point mode

4-point	In 4-point mode a window with a lower and upper hysteresis is formed. The switch points must fulfill the following condition: $BotOff \leq BotOn < TopOn \leq TopOff$ The hystereses can be 0. The switching behavior depends on parameter "inversion". The following figure shows the switching behavior when inversion is deactivated::
---------	--

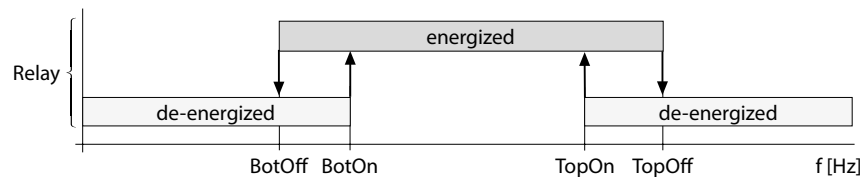

Fig. 11: 4-point mode

Mode to rotation to the left	<p>Pulse sequences rotation direction to the left If the rotation direction to left is detected, the relay is energized (inversion deactivated).</p>
------------------------------	--

Mode to rotation to the right (inversion deactivated)	<p>Pulse sequences rotation direction to the right If the rotation direction to right is detected, the relay is energized (inversion deactivated).</p>
--	--

## BotOn/BotOff/TopOn/TopOff

These parameters represent the switching threshold for 2-point and 4-point switching modes. The switching thresholds must not exceed the measuring range.

## Locking Function

This parameter depends on the physical state of the relay. Parameter "Inversion" is regarded.

Selection	Description
deactivated	In this selection the relay switches on and off corresponding to the measured value and selected configuration.
switched on	The relay switches on according to the measured value and selected configuration. It stays permanently locked on. The locked state is left after power on reset or detection of a failure.
switched off	The relay switches off according to the measured value and selected configuration. It stays permanently locked off. The locked state is left after power on reset.

## Switching On/Off Delay

The value of this parameter specifies the switch on/off delay after detection of of switch on/off condition.

Values between 0.0...999.9 s are possible.

## Inversion

Selection	Description
activated	This function enables the inversion of the switching state (instead of off, on and vice versa)
deactivated	If the Inversion function is disabled, the switching state is transferred to the digital output A1D without inversion according to the parameter setting.

### 6.3.3 Parameter-Check

- Before the verification of the parameterization PC-Connect must be disconnected and the device must be reset.
- The proof test (see „Appendix: Proof Test“) shall be executed in order to check the requested function and parameterization.
- The tests shall be executed even if the device was not parameterized.
- Within the proof tests each relevant parameter shall be checked for correct function.
- The device shall be locked against unintended operation/modification.
- The device must not parameterized during operation.
- The proof test shall be documented.

## 6.4 Operation

- If the device is used in low demand mode, proof tests shall be executed periodically according to T1 (see „Appendix: Proof Test“).
- Ensure that the plug connections and cables are always in good condition.
- The device must be replaced immediately if the terminals are faulty or the device has any visible faults.
- If cleaning is required, do not use any liquid or statically charging cleaning agent. Perform proof tests after each cleaning (see „Appendix: Proof Test“).
- The device must be replaced before remaining longer than 24 h within the safe state due to an internal failure

## 6.5 After operation

- ▶ Undo the terminal connection on the device.
- ▶ Remove the device from its rail fixing as shown in the figure:

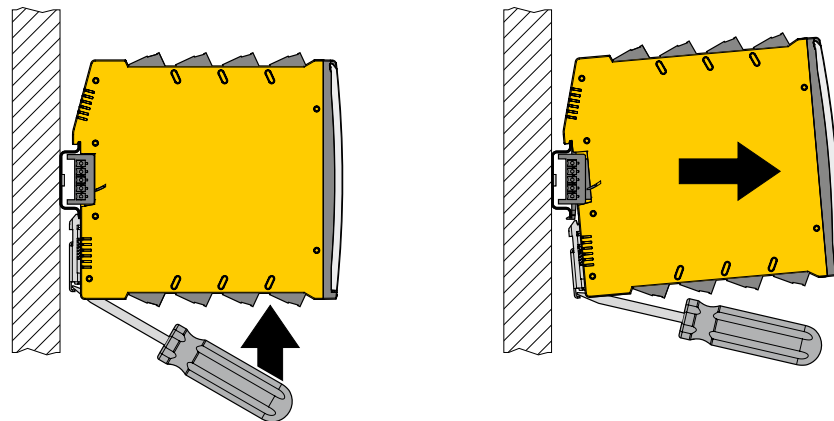

Fig. 12: Remove device

- ▶ Ensure the dispose of the device.

## 7 Appendix: Connection and wiring diagrams

The pin number assignment can be found at the front label.  
 Load resistance is (A1A, A2A):  $\leq 800 \Omega$

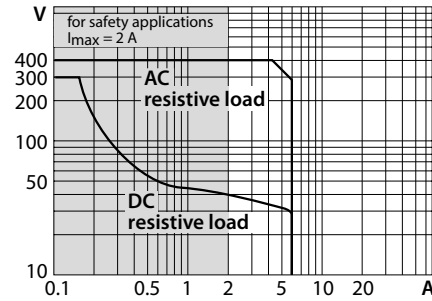

Fig. 13: Output relay load curve

The connection of a deactivated input is unnecessary.

IMX12-FI01-1SF-1I1R

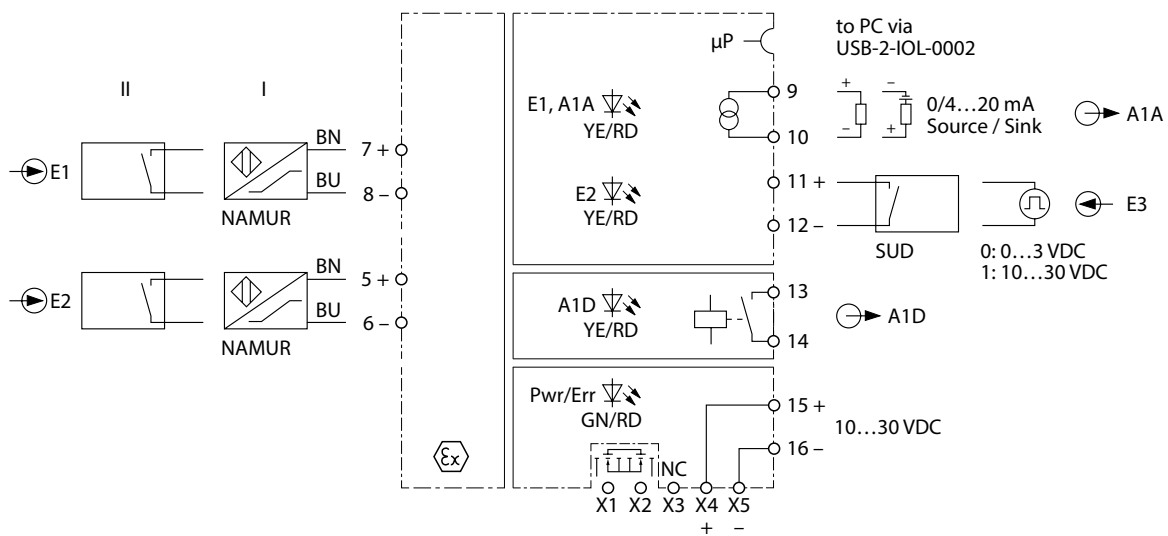

Fig. 14: Block diagram IMX12-FI01-1SF-1I1R

IM12-FI01-1SF-111R

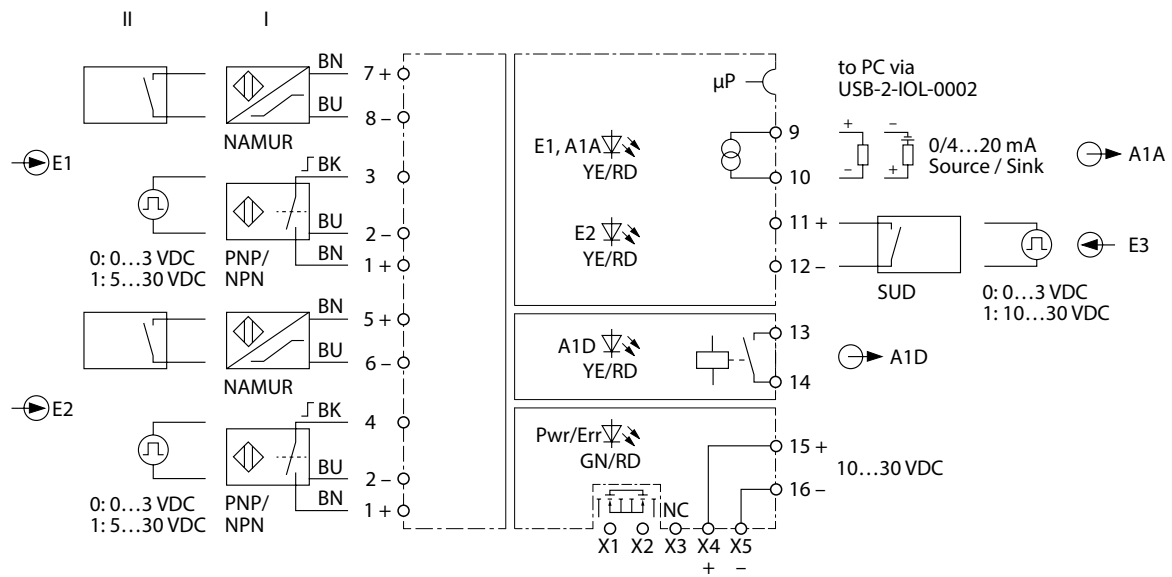

Fig. 15: Block diagram IM12-FI01-1SF-111R

IMX12-FI01-2SF-2I

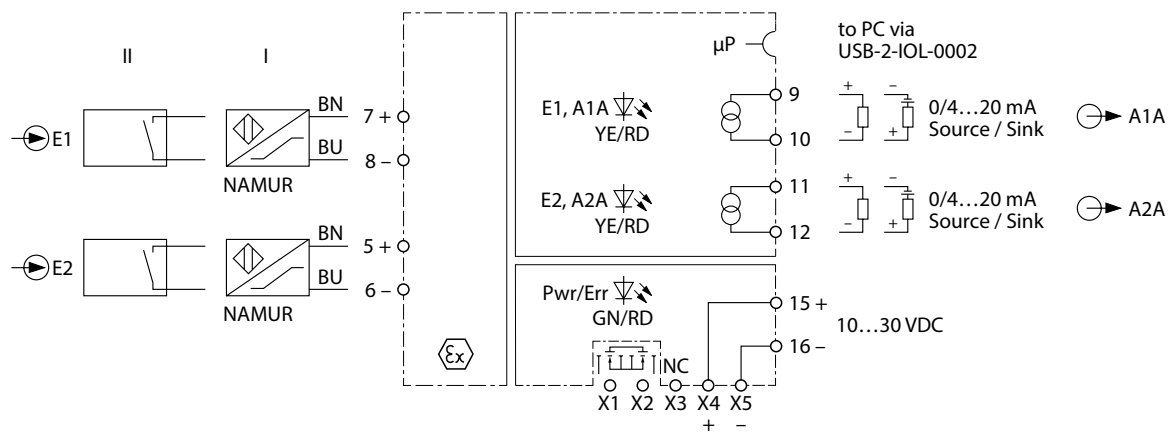

Fig. 16: Block diagram IMX12-FI01-2SF-2I

IM12-FI01-2SF-2I

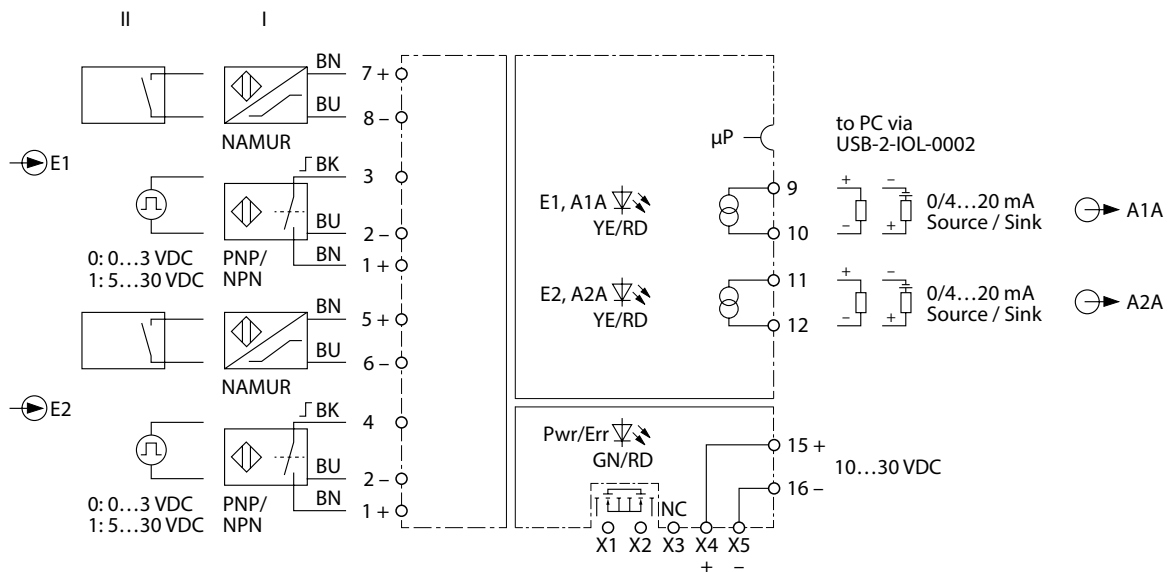

Fig. 17: Block diagram IM12-FI01-2SF-2I

## 8 Appendix: Terms and abbreviations

DC	Diagnostic Coverage
FIT	1 FIT is 1 failure per 10E09 hours
FMEDA	Failure Modes, Effects and Diagnostic Analysis
HFT	Hardware failure tolerance
$\lambda_{AU}$	Undetected Annunciation failure rate (per hour) Annunciation failures do not directly impact safety but impact the ability to detect a future fault (such as a fault in diagnostic circuit).
$\lambda_{DD}$	Detected dangerous failure rate (per hour)
$\lambda_{DU}$	Undetected dangerous failure rate (per hour)
$\lambda_{SD}$	Detected safe failure rate (per hour)
$\lambda_{SU}$	Undetected safe failure rate (per hour)
MTTR	Mean time to restoration (hour)
$PFD_{avg}$	Average probability of dangerous failure on demand
PFH	Probability of dangerous failure per hour
SFF	Safe Failure Fraction
SIL	Safety Integrity Level
T1	Proof test interval (hour)
Type A	"Non-complex" element (all failure modes are well defined); for details see 7.4.4.1.2 of IEC 61508-2
Type B	"Complex" element (using micro controllers or programmable logic); for details see 7.4.4.1.3 of IEC 61508-2

## 9 Appendix: Proof test

Proof tests shall be undertaken to reveal dangerous faults that are undetected by diagnostic tests. This means that it is necessary to specify how dangerous undetected faults which have been previously noted during the FMEDA can be detected during proof testing.

Ensure that the proof test is only carried out by qualified personnel.

A suggested proof test consists of the following steps:

Step	Action
1.	Bypass the safety functions and take appropriate action to avoid a false trip.
2.	Provide appropriate input-/control signals to the interface modules and verify the expected signal input/output conditions for the interfaces.
3.	Verify if internal fault detection is working in case it is activated.
4.	Provide appropriate input-/control signals to the interface modules and verify that the safety function is carried out correctly.
5.	Remove the bypass and otherwise restore normal operation.

This test will detect 98 % of possible dangerous undetected failures.

Once the test has been completed, document and archive the results.

## 10 Appendix: Document history

Document version	Date	Modifications
1.0	2017-05-03	Initial version
2.0	2018-07-16	More detailed explanation of temperature conditions
3.0	2026-01-29	SIL card removed

# TURCK

Your Global Automation Partner

Over 30 subsidiaries and  
60 representations worldwide!

10000673 | 2026/01



[www.turck.com](http://www.turck.com)